

## ST 3000 Smart Transmitter Series 100 Remote Diaphragm Seals Models

STR12D	0-10 to 0-400 inH <sub>2</sub> O	0-25 to 0-1000 mbar
STR13D	0-5 to 0-100 psid	0-0.35 to 0-7 bar
STR14G	0-5 to 0-500 psig	0-0.35 to 0-35 bar
STR17G	0-100 to 0-3000 psig	0-7 to 0-210 bar
STR14A	0-5 to 0-500 psia	0-0.35 to 0-35 bar

## Specification and Model Selection Guide

### Introduction

In 1983, Honeywell introduced the first Smart Pressure Transmitter—the ST 3000®. In 1989, Honeywell launched the first all digital, bi-directional protocol for smart field devices. Today, its ST 3000 Series 100 Remote Seal Transmitters continue to bring proven “smart” technology to a wide spectrum of measurement applications. Typical applications include high accuracy level measurement in pressurized vessels in the chemical and hydrocarbon processing industries. A second application consists of accurate flow measurement for slurries and high viscosity fluids in the chemical industry. Honeywell remote seal transmitters demonstrate proven reliability in hundreds on installations in a wide variety of industries and applications with a wide variety of secondary fill fluids for corrosive or high temperature process fluids.

All ST 3000 transmitters can provide a 4-20 mA output, Honeywell Digitally Enhanced (DE) output, HART® output, or FOUNDATION™ Fieldbus output. When digitally integrated with Honeywell’s Process Knowledge System™, EXPERION PKS™, ST 3000 instruments provide a more accurate process variable as well as advanced diagnostics.

Honeywell’s high-performance ST 3000 S100 transmitters lead the industry in:

- Accuracy
- Stability
- Reliability
- Rangeability
- Warranty

Includes Lifetime™ Transmitters:

- Total Accuracy =  $\pm 0.0375\%$
- Stability =  $\pm 0.01\%$  per year
- Reliability = 470 years MTBF
- Rangeability = 400 to 1
- Lifetime Warranty = 15 years



**Figure 1**—Series 100 Remote Seal Pressure Transmitters feature proven piezoresistive sensors and advanced seal technology with standard weld connections.

The devices provide comprehensive self-diagnostics to help users maintain high uptime, meet regulatory requirements, and attain high quality standards. S100 transmitters are ideal for critical applications, such as custody transfer of natural gas and energy and material balances, where accuracy and stability are of the utmost importance.

"Our commitment to Honeywell field instruments is based on seamless integration with our Honeywell system and the enhanced fault detection that the Honeywell DE protocol offers. Honeywell instruments also offer us a better way of ensuring database integrity over simple analog instruments. In addition, Honeywell's high-quality support has enabled us to better implement solutions to some of our more difficult problems. We have used Honeywell differential pressure smart transmitters for the past eight years. Based on their accuracy and low failure rates, we are now targeting critical flow applications that require the robustness that these transmitters bring."

DCS Systems Engineer  
International Integrated Oil Company

## Description of Diaphragm Seals

Diaphragm seals are traditionally used when a standard pressure transmitter should not be exposed to the process pressure directly. Diaphragm seals typically protect the pressure transmitter from one or more damaging aspects of the process media. Consideration for using a diaphragm seal should be made in the following circumstances.

- High Process Temperature
- Process Media is Viscous or Contains Suspended Solids
- Process Media is Subject to Solidifying
- Process Media is Corrosive
- Process Application Requires Sanitary Connections
- Process Application Subjects the Measuring Instrument to Hydrogen Permeation
- Tank Level Applications with Maintenance Intensive Wet Legs
- Tank Application with Density or Interface Measurements
- Measuring Instrument Requires Remote Mounting

The following diaphragm seals are standard from Honeywell (please call your local salesperson if you do not see the product you need for your application):

**Figure 2 - Flush Flange Seals** can be used with differential, gauge and absolute pressure transmitters and are available with 3" ANSI Class 150, ANSI Class 300 and DIN DN80-PN40 process connections. Flush flange seals can also be provided with Lowers. Lowers are essentially calibration rings, which allow flushing connections if needed – see Figure 31.



**Figure 2**

**Figure 3 - Flange Seal with Extended Diaphragm** can be used with differential, gauge and absolute pressure transmitters and are available with 3" and 4" ANSI Class 150, ANSI Class 300, DIN DN80-PN40 and DIN DN100-PN40 process connections. 2", 4" and 6" extension lengths are available.



**Figure 3**

**Figure 4 - Pancake Seals** can be used with differential, gauge and absolute pressure transmitters and are available with 3" ANSI Class 150, 300 and 600 process connections.









**Figure 4**

**Figure 5 - Chemical Tee "Taylor" Wedge seals** can be used with differential pressure transmitters and are available with Taylor Wedge 5" O.D. process connection.



**Figure 5**

<b>Description of Diaphragm Seals</b>	
<p><b>Figure 6 - Seals with Threaded Process Connections</b> can be used with differential, gauge and absolute pressure transmitters and are available with 1/2", 3/4" and 1" NPT Female process connections.</p>	 <p style="text-align: center;"><b>Figure 6</b></p>
<p><b>Figure 7 - Sanitary Seals</b> can be used with differential, gauge and absolute pressure transmitters and are available with 3" and 4" Tri-Clover-Tri-Clamp process connections.</p>	 <p style="text-align: center;"><b>Figure 7</b></p>
<p><b>Figure 8 - Saddle Seals</b> can be used with differential, gauge and absolute pressure transmitters and are available with 3" and 4" (6 bolt or 8 bolt designs) process connections.</p>	 <p style="text-align: center;"><b>Figure 8</b></p>
<p><b>Figure 9 - Calibration Rings</b> are available with Flush Flange Seals and Pancake Seals. Flushing ports (1/4" or 1/2") are available with calibration rings.</p>	 <p style="text-align: center;"><b>Figure 9</b></p>
<p><b>Figure 10 - Stainless Steel Armor and PVC Coated Stainless Steel Armor Capillaries</b> are available with Honeywell Remote Seal Solutions.</p>	 <p style="text-align: center;"><b>Figure 10</b></p>
<p><b>Figure 11 - 2" Stainless Steel Nipples</b> are available for Close-Coupled remote seal solutions.</p>	 <p style="text-align: center;"><b>Figure 11</b></p>

**Figure 12 - Welded Meter Body for All-Welded Remote Seal Solution.** The welded ST 3000 meter body is an important part of an All-Welded Remote Seal Solution, which is commonly used in Vacuum applications.



**Figure 12**

## Description

The ST 3000 transmitter can replace any 4 to 20 mA output transmitter in use today and operates over a standard two-wire system.

The measuring means is a piezoresistive sensor, which actually contains three sensors in one. It contains a differential pressure sensor, a temperature sensor, and a static pressure sensor.

Microprocessor-based electronics provide higher span-turndown ratio, improved temperature and pressure compensation, and improved accuracy.

The transmitter's meter body and electronics housing resist shock, vibration, corrosion, and moisture. The electronics housing contains a compartment for the single-board electronics, which is isolated from an integral junction box. The single-board electronics is replaceable and interchangeable with any other ST 3000 Series 100 or Series 900 model transmitter.

Like other Honeywell transmitters, the ST 3000 features two-way communication and configuration capability between the operator and the transmitter through several Honeywell field-rated portable configuration devices, including the Smart Field Communicator (SFC) and the Multiple Communication Configurator (MC ToolKit). While both are made for in-field use, the MC Toolkit also can be ordered for use in intrinsically safe environments.

The SCT 3000 Smartline® Configuration Toolkit provides an easy way to configure instruments using a personal computer. The toolkit enables configuration of devices before shipping or installation. The SCT 3000 can operate in the offline mode to configure an unlimited number of devices. The database can then be loaded down-line during commissioning.

## Features

- Choice of linear or square root output conformity is a simple configuration selection.
- Direct digital integration with Experion PKS and other control systems provides local measurement accuracy to the system level without adding typical A/D and D/A converter inaccuracies.
- Unique piezoresistive sensor automatically compensates input for temperature and static pressure. Added "smart" features include configuring lower and upper range values, simulating accurate analog output, and selecting preprogrammed engineering units for display.
- Smart transmitter capabilities with local or remote interfacing means significant manpower efficiency improvements in commissioning, start-up, and ongoing maintenance functions.

## Specifications

### Operating Conditions – All Models

Parameter	Reference Condition		Rated Condition		Operative Limits		Transportation and Storage	
	°C	°F	°C	°F	°C	°F	°C	°F
<b>Ambient Temperature *</b>	25 ±1	77 ±2	—	—	—	—	-55 to 90	-67 to 194
<b>Humidity</b> % RH	10 to 55		0 to 100		0 to 100		0 to 100	
<b>Maximum Allowable Working Pressure (MAWP)</b>	MAWP is minimum of Body Rating or Seal Rating (See Model Selection Guide for Seal MAWP)							
	<b>Body</b>		<b>MAWP</b>					
	STR12D		2500 psig (172 bar) Bolted Process Heads Table I __ A					
	STR13D		2500 psig (172 bar) Bolted Process Heads Table I __ A					
	STR12D		1450 psig (100 bar) All Welded Process Heads Table I __ C					
	STR13D		1450 psig (100 bar) All Welded Process Heads Table I __ C					
	STR14G		500 psig (35 bar)					
	STR17G		3000psig (207 bar)					
	STR14A		500 psia (35 bar).					
<b>Vacuum Region - Minimum Pressure</b> mmHg absolute	Atmospheric (See Figure 15 for vacuum limitations.)							
<b>Supply Voltage, Current, and Load Resistance</b>	<b>Voltage Range:</b>		10.8 to 42.4 Vdc at terminals					
	<b>Current Range:</b>		3.0 to 21.8 mA					
	<b>Load Resistance:</b>		0 to 1440 ohms (as shown in Figure 16)					

\* Ambient Temperature Limit is a function of Process Interface Temperature. (See Figure 13.)

**Performance Under Rated Conditions \* - Model STR12D (0-10 to 0-400 inH<sub>2</sub>O)**

Parameter	Description
<b>Upper Range Limit **</b> inH <sub>2</sub> O mbar	400 (39.2°F/4°C is standard reference temperature for inH <sub>2</sub> O range.) 1000
<b>Minimum Span</b> inH <sub>2</sub> O mbar	10 Note: Recommended minimum span in square root mode is 20 inH <sub>2</sub> O (50 mbar). 25
<b>Turndown Ratio</b>	40 to 1
<b>Zero Elevation and Suppression</b>	No limit except minimum span within ±100% URL.
<p><b>Accuracy</b> (Reference – Includes combined effects of linearity, hysteresis, and repeatability)</p> <ul style="list-style-type: none"> <li>Accuracy includes residual error after averaging successive readings.</li> <li>For FOUNDATION Fieldbus use Digital Mode specifications. For HART use Analog Mode specifications.</li> </ul>	<p><b>In Analog Mode:</b> ±0.2% of calibrated span or upper range value (URV), whichever is greater, terminal based. For URV below reference point (50 inH<sub>2</sub>O), accuracy equals: ±0.1 + 0.1 <math>\left(\frac{50 \text{ inH}_2\text{O}}{\text{span inH}_2\text{O}}\right)</math> or ±0.1 + 0.1 <math>\left(\frac{125 \text{ mbar}}{\text{span mbar}}\right)</math> in % of span</p> <p><b>In Digital Mode:</b> ±0.175% of calibrated span or upper range value (URV), whichever is greater, terminal based. For URV below reference point (50 inH<sub>2</sub>O), accuracy equals: ±0.075 + 0.10 <math>\left(\frac{50 \text{ inH}_2\text{O}}{\text{span inH}_2\text{O}}\right)</math> or ±0.075 + 0.10 <math>\left(\frac{125 \text{ mbar}}{\text{span mbar}}\right)</math> in % of span</p>
<b>Combined Zero and Span Temperature Effect per 28°C (50°F) ***</b>	<p><b>In Analog Mode:</b> ±1.2% of span. For URV below reference point (200 inH<sub>2</sub>O), effect equals: ±0.2 + 1.0 <math>\left(\frac{200 \text{ in H}_2\text{O}}{\text{span in H}_2\text{O}}\right)</math> or ±0.2 + 1.0 <math>\left(\frac{500 \text{ mbar}}{\text{span mbar}}\right)</math> In % span</p> <p><b>In Digital Mode:</b> ±1.175% of span. For URV below reference point (200 inH<sub>2</sub>O), effect equals: ±0.175 + 1.0 <math>\left(\frac{200 \text{ in H}_2\text{O}}{\text{span in H}_2\text{O}}\right)</math> or ±0.175 + 1.0 <math>\left(\frac{500 \text{ mbar}}{\text{span mbar}}\right)</math> In % span</p>

\* Performance specifications are based on reference conditions of 25°C (77°F), zero (0) static pressure, 10 to 55% RH, and 316L Stainless Steel barrier diaphragm.

\*\* Transmitter URL limit or maximum seal pressure rating, whichever is lower.

\*\*\* Specification applies to transmitters with 2 seals only. Apply 1.5 times factor to temperature effect for capillary lengths greater than 10 feet.

**Performance Under Rated Conditions \* - Model STR13D (0-5 to 0-100 psid)**

Parameter	Description
<b>Upper Range Limit **</b> psid bar	100 7
<b>Minimum Span</b> psid bar	5 0.35
<b>Turndown Ratio</b>	20 to 1
<b>Zero Elevation and Suppression</b>	No limit except minimum span within -18% and +100% of URL. Specifications valid from -5% to 100% of URL.
<p><b>Accuracy</b> (Reference – Includes combined effects of linearity, hysteresis, and repeatability)</p> <ul style="list-style-type: none"> <li>• <i>Stated accuracy <b>does not</b> apply for models with 2.9 inch diameter remote seal diaphragms.</i></li> <li>• <i>Accuracy includes residual error after averaging successive readings.</i></li> <li>• <i>For FOUNDATION Fieldbus use Digital Mode specifications. For HART use Analog Mode specifications.</i></li> </ul>	<p><b>In Analog Mode:</b> ±0.1% of calibrated span or upper range value (URV), whichever is greater, terminal based. For URV below reference point (30 psi), accuracy equals: ±0.05 + 0.05 <math>\left(\frac{30 \text{ psi}}{\text{span psi}}\right)</math> or ±0.05 + 0.05 <math>\left(\frac{2 \text{ bar}}{\text{span bar}}\right)</math> in % of span</p> <p><b>In Digital Mode:</b> ±0.075% of calibrated span or upper range value (URV), whichever is greater, terminal based. For URV below reference point (30 psi), accuracy equals: ±0.025 + 0.05 <math>\left(\frac{30 \text{ psi}}{\text{span psi}}\right)</math> or ±0.025 + 0.05 <math>\left(\frac{2 \text{ bar}}{\text{span bar}}\right)</math> in % of span</p>
<b>Combined Zero and Span Temperature Effect per 28°C (50°F) ***</b>	<p><b>In Analog Mode:</b> ±0.33% of span. For URV below reference point (60 psi), effect equals: ±0.05 + 0.2 <math>\left(\frac{60 \text{ psi}}{\text{span psi}}\right)</math> or ±0.05 + 0.28 <math>\left(\frac{4 \text{ bar}}{\text{span bar}}\right)</math> In % span</p> <p><b>In Digital Mode:</b> ±0.305% of span. For URV below reference point (60 psi), effect equals: ±0.025 + 0.25 <math>\left(\frac{60 \text{ psi}}{\text{span psi}}\right)</math> or ±0.025 + 0.28 <math>\left(\frac{4 \text{ bar}}{\text{span bar}}\right)</math> In % span</p>

\* Performance specifications are based on reference conditions of 25°C (77°F), zero (0) static pressure, 10 to 55% RH, and 316L Stainless Steel barrier diaphragm.

\*\* Transmitter URL limit or maximum seal pressure rating, whichever is lower.

\*\*\* Specification applies to transmitters with 2 seals only. Apply 1.5 times factor to temperature effect for capillary lengths greater than 10 feet.

**Performance Under Rated Conditions \* - Model STR14G (0-5 to 0-500 psig)**

Parameter	Description
Upper Range Limit ** <b>psig</b> <b>bar</b>	500 35
Minimum Span <b>psig</b> <b>bar</b>	5 0.35
Turndown Ratio	100 to 1
Zero Elevation and Suppression	No limit except minimum span from absolute zero to 100% of URL. Specifications valid over this range.
<p><b>Accuracy</b> (Reference – Includes combined effects of linearity, hysteresis, and repeatability)</p> <ul style="list-style-type: none"> <li>• Accuracy includes residual error after averaging successive readings.</li> <li>• For FOUNDATION Fieldbus use Digital Mode specifications. For HART use Analog Mode specifications.</li> </ul>	<p><b>In Analog Mode:</b> ±0.1% of calibrated span or upper range value (URV), whichever is greater. For URV below reference point (20 psi), accuracy equals: ±0.05 + 0.05 <math>\left(\frac{20 \text{ psi}}{\text{span psi}}\right)</math> or ±0.05 + 0.05 <math>\left(\frac{1.4 \text{ bar}}{\text{span bar}}\right)</math> in % of span</p> <p><b>In Digital Mode:</b> ±0.075% of calibrated span or upper range value (URV), whichever is greater. For URV below reference point (20 psi), accuracy equals: ±0.025 + 0.05 <math>\left(\frac{20 \text{ psi}}{\text{span psi}}\right)</math> or ±0.025 + 0.05 <math>\left(\frac{1.4 \text{ bar}}{\text{span bar}}\right)</math> in % of span</p>

\* Performance specifications are based on reference conditions of 25°C (77°F), zero (0) static pressure, 10 to 55% RH, and 316L Stainless Steel barrier diaphragm.

\*\* Transmitter URL limit or maximum seal pressure rating, whichever is lower.



### Performance Under Rated Conditions \* - Model STR14A (0-5 to 0-500 psia)

Parameter	Description
Upper Range Limit **      psia bar absolute	500 35
Minimum Span                      psia bar absolute	5 0.35
Turndown Ratio	100 to 1
Zero Elevation and Suppression	No limit except minimum span from 0 to 100% URL.
<b>Accuracy</b> (Reference – Includes combined effects of linearity, hysteresis, and repeatability) <ul style="list-style-type: none"> <li>• Accuracy includes residual error after averaging successive readings.</li> <li>• For FOUNDATION Fieldbus use Digital Mode specifications. For HART use Analog Mode specifications.</li> </ul>	<b>In Analog Mode:</b> ±0.1% of calibrated span or upper range value (URV), whichever is greater. For URV below reference point (20 psi), accuracy equals: $\pm 0.05 + 0.05 \left( \frac{20 \text{ psi}}{\text{span psi}} \right)$ or $\pm 0.05 + 0.05 \left( \frac{1.4 \text{ bar}}{\text{span bar}} \right)$ in % of span  <b>In Digital Mode:</b> ±0.075% of calibrated span or upper range value (URV), whichever is greater. For URV below reference point (20 psi), accuracy equals: $\pm 0.025 + 0.05 \left( \frac{20 \text{ psi}}{\text{span psi}} \right)$ or $\pm 0.025 + 0.05 \left( \frac{1.4 \text{ bar}}{\text{span bar}} \right)$ in % of span

\* Performance specifications are based on reference conditions of 25°C (77°F), zero (0) static pressure, 10 to 55% RH, and 316L Stainless Steel barrier diaphragm.

\*\* Transmitter URL limit or maximum seal pressure rating, whichever is lower.

### Performance Under Rated Conditions – General for all Models

Parameter	Description
Output (two-wire)	Analog 4 to 20 mA or digital communications DE mode. Options available for FOUNDATION Fieldbus and HART protocol.
Supply Voltage Effect	±0.005% of span per volt.
Damping Time Constant	Adjustable from 0 to 32 seconds digital damping.
RFI Protection (Standard)	Negligible (20 to 1000 MHz at 30 volts per meter).
CE Conformity (Europe)	89/336/EEC, Electromagnetic Compatibility (EMC) Directive.
NAMUR NE 43 Compliance Option	Transmitter failure information is generated when the measuring information is invalid or no longer present. Failure information is transmitted as a current signal but outside the normal 4-20 mA measurement signal level. Transmitter failure values are: ≤ 3.6 mA and ≥ 21.0 mA. The normal signal range is ≥ 3.8 mA and ≤ 20.5 mA.
SIL 2/3 Compliance	SIL certified to IEC 61508 for non-redundant use in SIL 2 related Safety Systems (single use) and for redundant (multiple) use in SIL 3 Safety Systems through TÜV Nord Sys Tec GmbH & Co. KG under the following standards: IEC61508-1: 1998; IEC 61508-2: 2000; IEC61508-3: 1998.

## Physical and Approval Bodies

Parameter	Description
Process Interface	See Model Selection Guide for Material Options for desired seal type.
Seal Barrier Diaphragm	316L Stainless Steel, Monel, Hastelloy C, Tantalum
Seal Gasket Materials	Klinger C-4401 (non-asbestos)      Grafoil      Teflon      Gylon 3510
Mounting Bracket	Carbon Steel (Zinc-Chromate plated) or Stainless Steel.
Fill Fluid (Meter Body)	Silicone (DC 200)      S.G. @ 25°C = 0.94 CTFE (Chlorotrifluoroethylene)      S.G. @ 25°C = 1.89
Fill Fluid (Secondary)	Silicone (DC 200)      S.G. @ 25°C = 0.94 CTFE (Chlorotrifluoroethylene)      S.G. @ 25°C = 1.89 Silicone (DC 704)      S.G. @ 25°C = 1.07 NEOBEE M-20      S.G. @ 25°C = 0.90 Syltherm 800      S.G. @ 25°C = 0.93
Electronic Housing	Epoxy-Polyester hybrid paint. Low copper-aluminum alloy. Meets NEMA 4X (watertight) and NEMA 7 (explosion proof). Stainless steel optional.
Capillary Tubing	Armored Stainless Steel or PVC Coated Armored Stainless Steel. <b>Length:</b> 5, 10, 15, 20, 25, and 35 feet (1.5, 3, 4.6, 6.1, 7.5, and 10.7 meters). A 2 inch (51 millimeter) S.S. close-coupled nipple is also available. See Model Selection Guide. Refer to Figure 14 for guide to maximum capillary length vs. diaphragm diameter.
Wiring	Accepts up to 16 AWG (1.5 mm diameter).
Mounting	See Figure 17.
Dimensions	<b>Transmitter:</b> See Figures 20a and 20b. <b>Seal:</b> See Figures 21 through 31.
Net Weight	<b>Transmitter:</b> 15.4 pounds (7 Kg). Total weight is dependent on seal type and capillary length.
Approval Bodies	
Factory Mutual	<b>Explosion Proof:</b> Approved as Explosion Proof for Class I, Division 1, Groups A, B, C, D locations, <b>Dust Ignition Proof:</b> Approved as Dust Ignition Proof for Class II, III, Division 1, Groups E, F, G locations, <b>Intrinsically Safe:</b> Approved as Intrinsically Safe for for Class I, II, III, Division 1, Groups A, B, C, D, E, F, G locations. <b>Nonincendive:</b> Approved as Nonincendive for Class I, Division 2, Groups A, B, C, D locations.
CSA	<b>Explosion Proof:</b> Approved as Explosion Proof for Class I, Division 1, Groups B, C, D locations, <b>Dust Ignition Proof:</b> Approved as Dust Ignition Proof for Class II, III, Division 1, Groups E, F, G locations, <b>Intrinsically Safe:</b> Approved as Intrinsically Safe for Class I, II, III, Division 1, Groups A, B, C, D, E, F, G locations.
Canadian Registration Number (CRN)	All ST 3000 model designs, except SATG19L, STG99L, STG170 and STG180 have been registered in all provinces and territories in Canada and are marked CRN:0F8914.5c.
ATEX	<b>Intrinsically Safe, Zone 0/1:</b> EEx ia IIC T4, T5, T6 <b>Flameproof/Zone 1:</b> EEx d IIC T5, T6 (enclosure IP 66/67) <b>Non-Sparking, Zone 2:</b> EEx nA, IIC T6 (enclosure IP 66/67) <b>Multiple Markings:</b> Ex II 1 G: EEx ia IIC T4, T5, T6, Ex II 2 G: EExd IIC T5, T6 Ex II 3 G: EEx nA, IIC T6 (Honeywell) (enclosure IP 66/67)
SA (Australian)	<b>Intrinsically Safe:</b> EX ia IIC T4 <b>Non-Sparking:</b> Ex n IIC T6 (T4 with SM option)
INMETRO (Brazil)	<b>Flame-Proof, Zone 1:</b> EX d IIC T5

Parameter	Description
<b>Pressure Equipment Directive (97/23/EC)</b>	The ST 3000 pressure transmitters listed in this Specification have no pressurized internal volume or have a pressurized internal volume rated less than 1,000 bar (14,500 psig) and/or have a maximum volume of less than 0.1 liter. Therefore, these transmitters are either; not subject to the essential requirements of the directive 97/23/EC (PED, Annex 1) and shall not have the CE mark, or the manufacturer has the free choice of a module when the CE mark is required for pressures > 200 bar (2,900 psig).

**NOTE:** Pressure transmitters that are part of safety equipment for the protection of piping (systems) or vessel(s) from exceeding allowable pressure limits, (equipment with safety functions in accordance with Pressure Equipment Directive 97/23/EC article 1, 2.1.3), require separate examination.

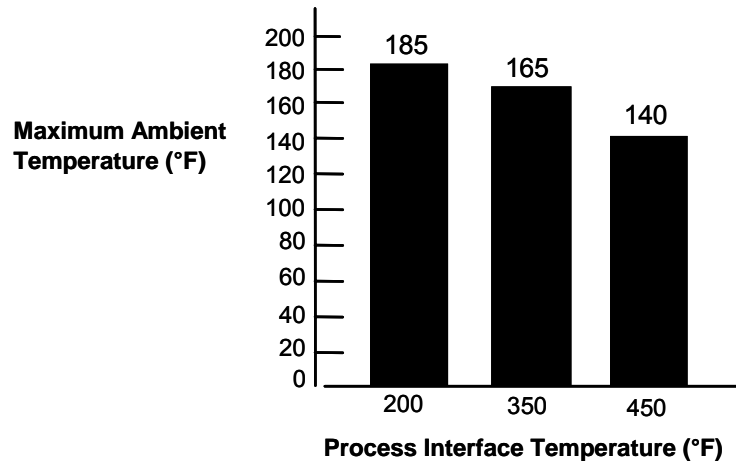

Figure 13—Ambient temperature and process interface chart.

**Transmitter Minimum Span and Maximum Capillary Length**

**Minimum recommended span for STR12D and STR13D DP Transmitter with two Remote Seals**

Diaphragm Size	Capillary						Capillary Length maximum
	5'	10'	15'	20'	30'	35'	
2.4	200 iwc	-	-	-	-	-	5'
2.9	100 iwc	125 iwc	150 iwc	175 iwc	-	-	20'
3.5	16 iwc	20 iwc	24 iwc	28 iwc	36 iwc	40 iwc	35'
4.1	12 iwc	15 iwc	18 iwc	21 iwc	27 iwc	30 iwc	35'

**Minimum recommended span for STR12D and STR13D DP Transmitter with one Remote Seal**

Diaphragm Size	Direct Mount	Capillary						Capillary Length maximum
		5'	10'	15'	20'	30'	35'	
2.4	20 psig	30 psig	-	-	-	-	-	5'
2.9	10 psig	15 psig	20 psig	25 psig	30 psig	-	-	20'
3.5	50 iwc	80 iwc	100 iwc	120 iwc	140 iwc	180 iwc	200 iwc	35'
4.1	40 iwc	60 iwc	80 iwc	100 iwc	120 iwc	160 iwc	180 iwc	35'

**Minimum recommended span for STR14G, STR14A, STR17G Transmitter with Remote Seal**

Diaphragm Size	Direct Mount	Capillary						Capillary Length maximum
		5'	10'	15'	20'	30'	35'	
2.0	25 psi	30 psi	40 psi	50 psi	-	-	-	15'
2.4	10 psi	15 psi	20 psi	25 psi	30 psi	40 psi	50 psi	35'
2.9	8 psi	9 psi	10 psi	11 psi	12 psi	14 psi	15 psi	35'
3.5	5 psi	5 psi	5 psi	5 psi	5 psi	7 psi	8 psi	35'
4.1	5 psi	5 psi	5 psi	5 psi	5 psi	7 psi	8 psi	35'

Minimum span is the higher of the value from the table above or the value defined under Performance Conditions for the range transmitter

Figure 14—Maximum capillary length and diaphragm size chart.

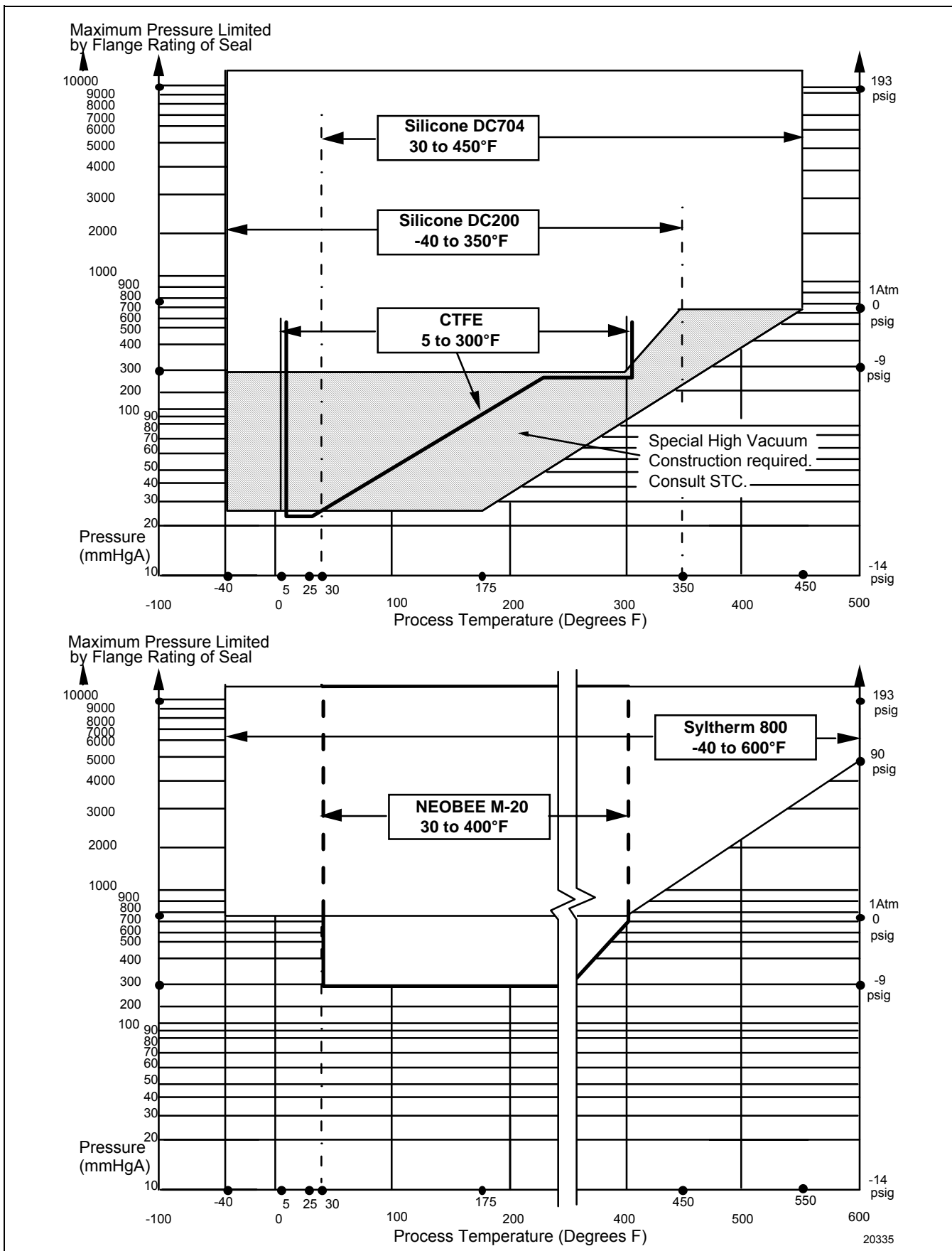

Figure 15—ST 3000 Remote Seals operable limits for pressure vs. temperature.

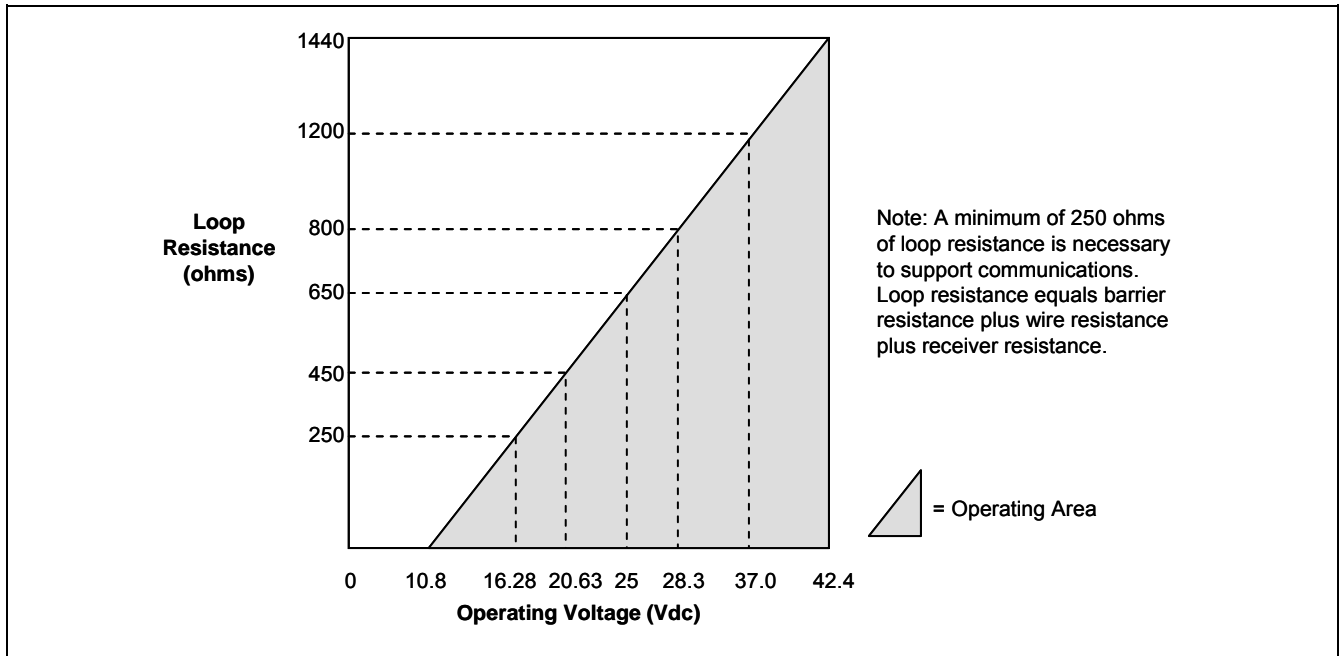

Figure 16—Supply voltage/loop resistance chart.

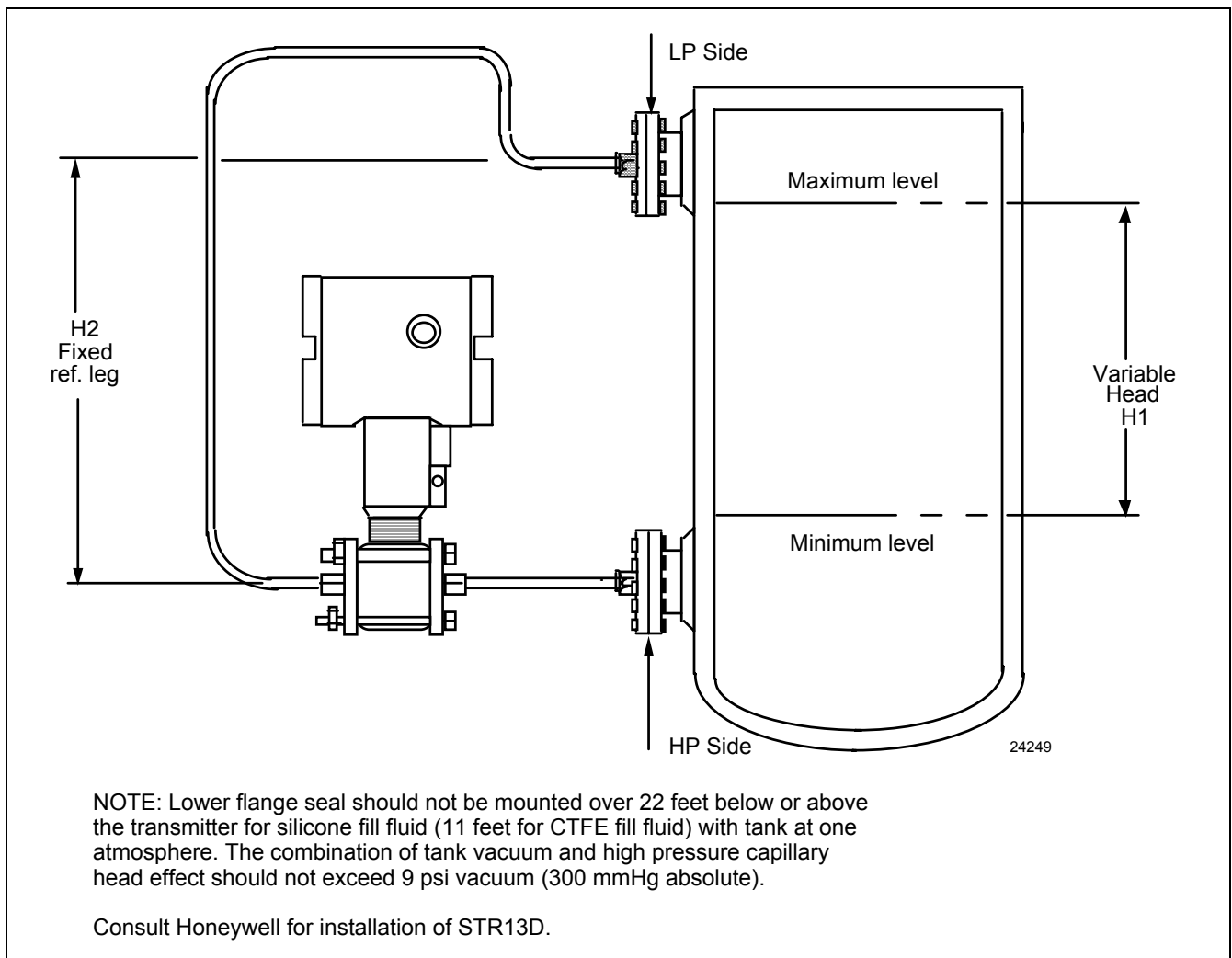

Figure 17—The ST 3000 transmitter with remote diaphragm seals shown mounted on a tank.

**Application Data\***

**Liquid Level: Closed Tank**

Determine the minimum and maximum pressure differentials to be measured (Figure 18).

$$\begin{aligned}
 P_{\text{Min}} &= (SG_p \times a) - (SG_f \times d) \\
 &= \text{LRV when HP at bottom of tank} \\
 &= -\text{URV when LP at bottom of tank}
 \end{aligned}$$

$$\begin{aligned}
 P_{\text{Max}} &= (SG_p \times b) - (SG_f \times d) \\
 &= \text{URV when HP at bottom of tank} \\
 &= -\text{LRV when LP at bottom of tank}
 \end{aligned}$$

Where:

Minimum level at 4 mA  
Maximum level at 20 mA

a = distance between bottom tap and minimum level

b = distance between bottom tap and maximum level

d = distance between taps

SG<sub>f</sub> = Specific Gravity of capillary fill fluid (see page 11 for values)

SG<sub>p</sub> = Specific Gravity of process fluid

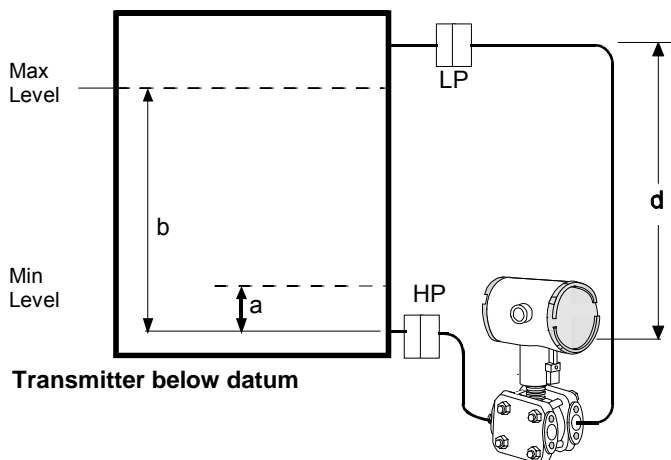
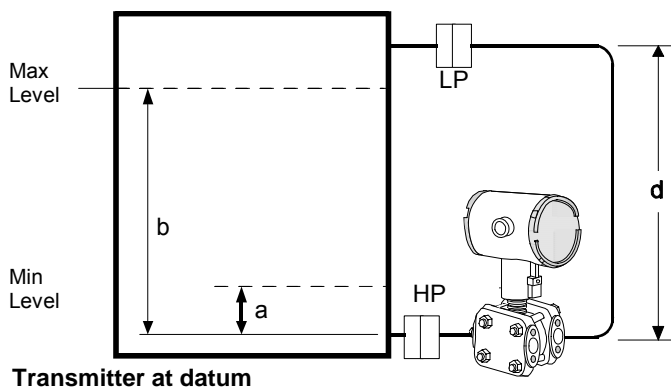
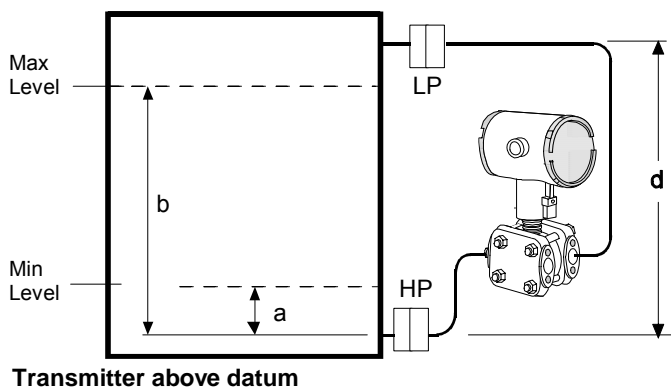

24253

**Figure 18**—Closed tank liquid level measurement distances.

\* Contact STC-Phoenix concerning applications for model STR13D.

**Density or Interface\***

Calculate the minimum and maximum pressure differentials to be measured.

$$P_{\min} = (SG_{\min} - SG_f) \times (d);$$

minimum density, 4mA output

$$P_{\max} = (SG_{\max} - SG_f) \times (d);$$

maximum density, 20mA output

Where:

d = distance between the taps

SG<sub>max</sub> = maximum Specific Gravity

SG<sub>min</sub> = minimum Specific Gravity

SG<sub>f</sub> = Specific Gravity of capillary fill fluid (see page 11 for values)

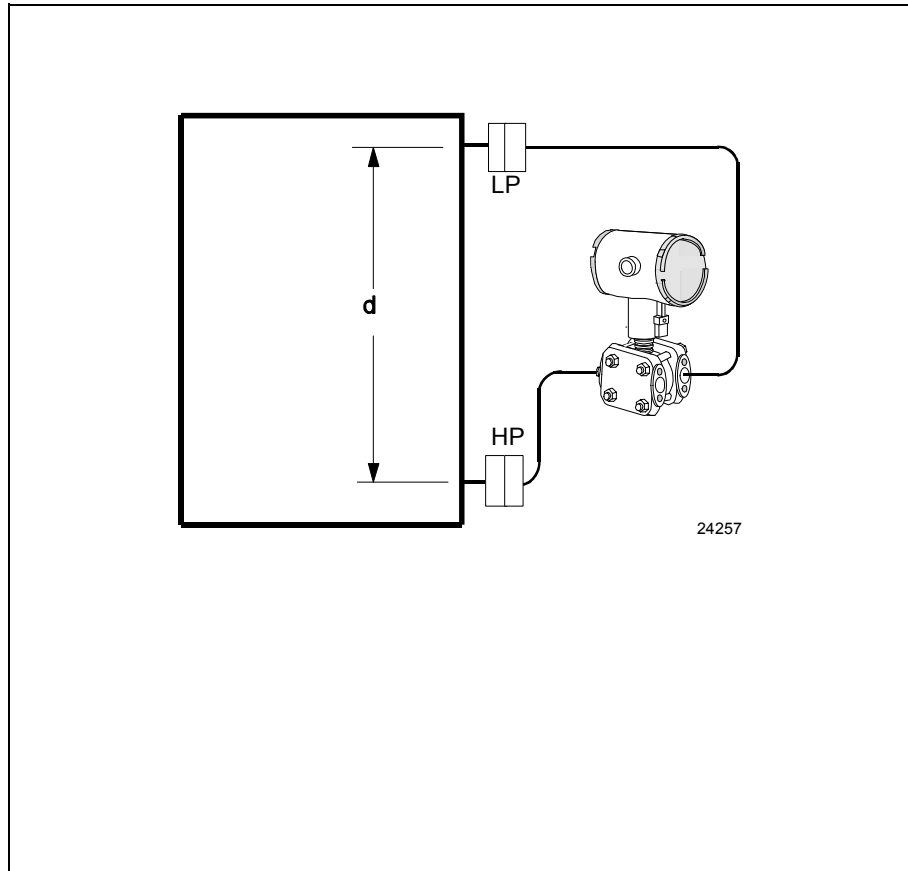

**Figure 19**—Density, direct acting instrument configuration.

\* Contact STC-Phoenix concerning applications for model STR13D.

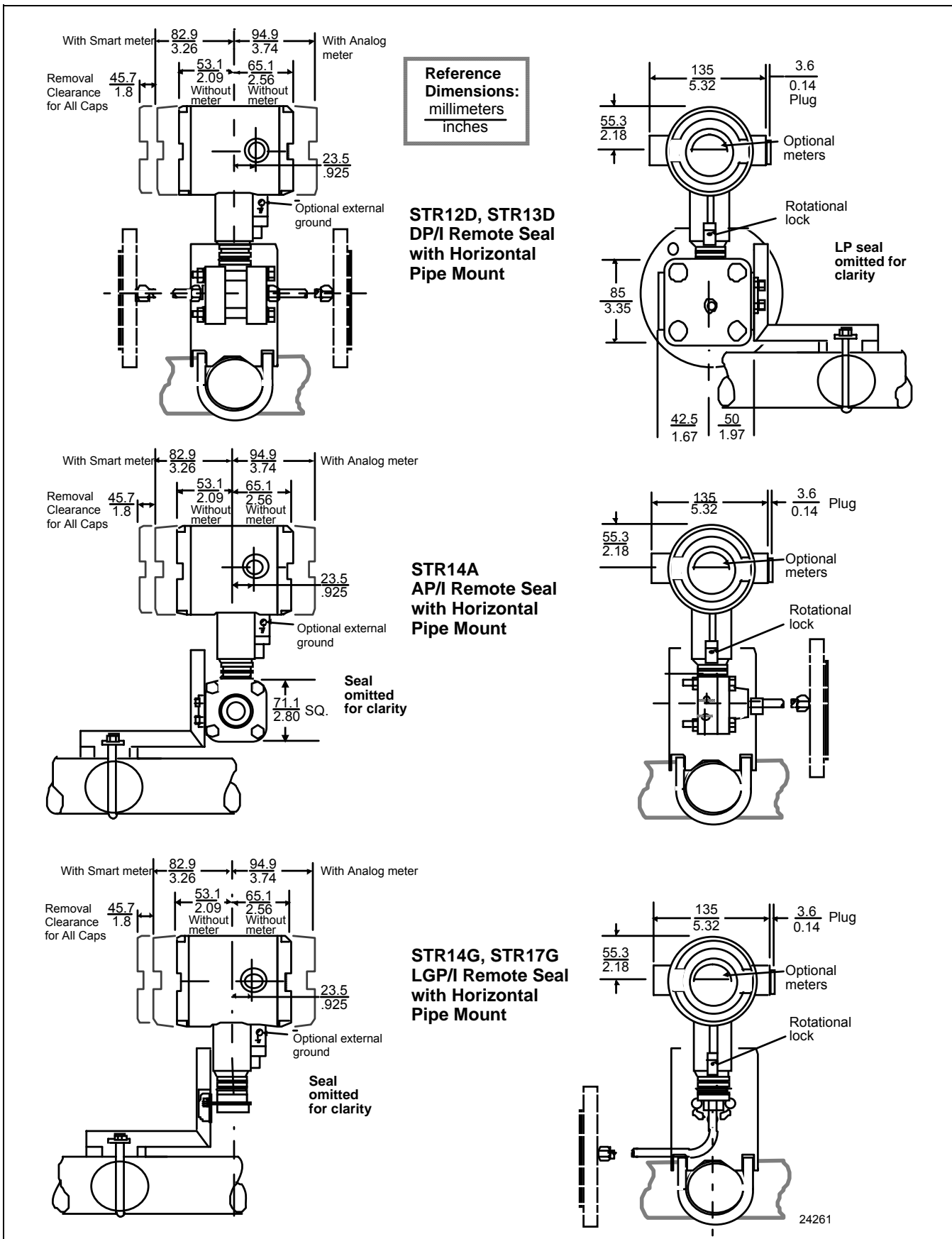
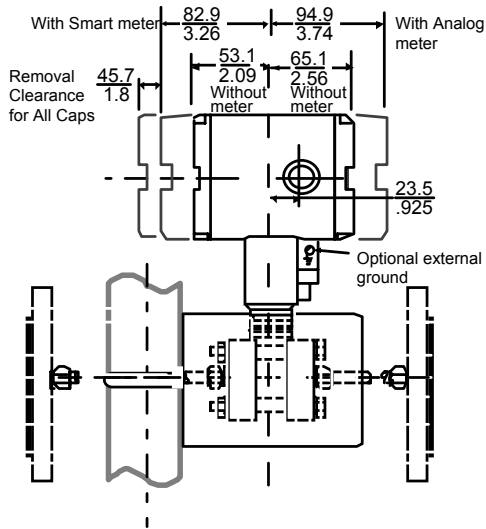
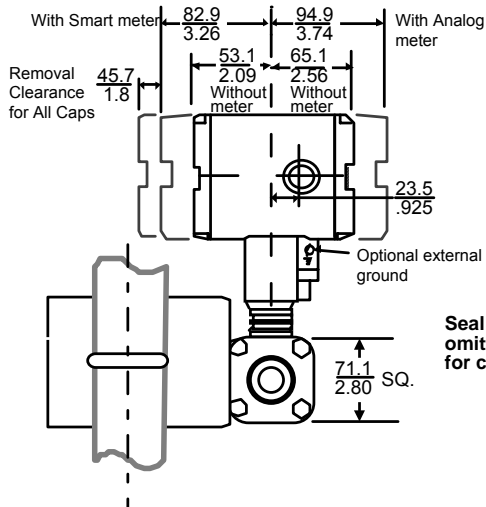
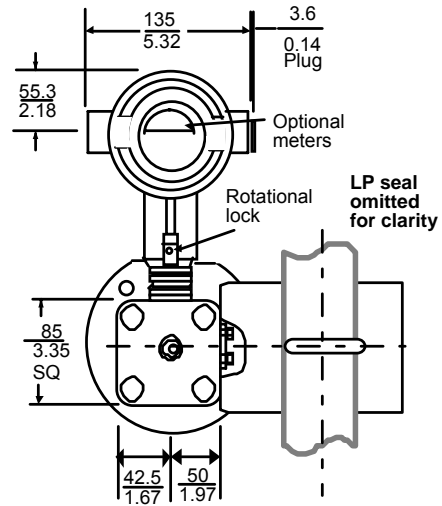

Figure 20a —Approximate horizontal mounting dimensions for Remote Seal Transmitter.



**Reference Dimensions:**  
millimeters  
inches

**STR12D, STR13D  
DP/I Remote Seal  
with Vertical  
Pipe Mount**



**STR14A  
AP/I Remote Seal  
with Vertical  
Pipe Mount**

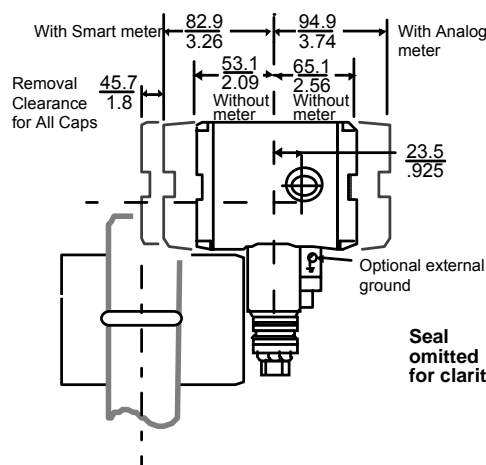
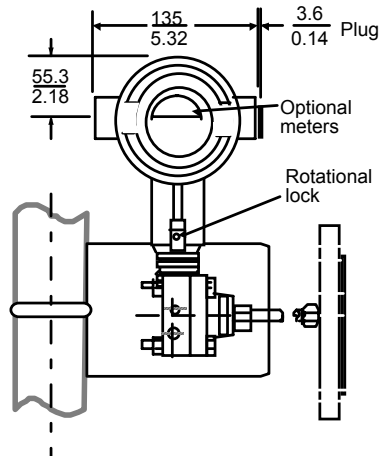

**STR14G, STR17G  
LGP/I Remote Seal  
with Vertical Pipe  
Mount (Flat Bracket)**

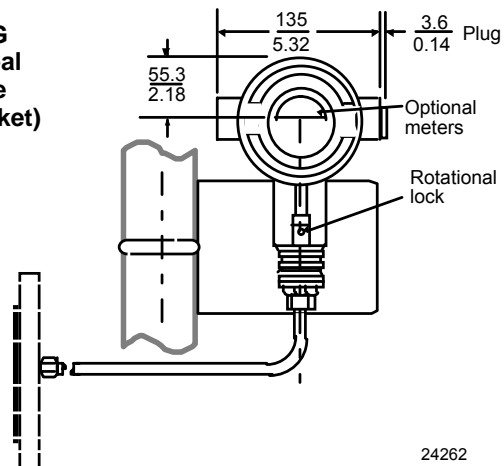

24262

**Figure 20b** —Approximate vertical mounting dimensions for Remote Seal Transmitter.

Options	Ordering Information
<p><b>Mounting Bracket</b> The angle mounting bracket is available in either zinc-plated carbon steel or stainless steel and is suitable for horizontal or vertical mounting on a two inch (50 millimeter) pipe, as well as wall mounting. An optional flat mounting bracket is also available in carbon steel for two inch (50 millimeter) pipe mounting.</p> <p><b>Indicating Meter (Options ME and SM)</b> Two integral meter options are available. An analog meter (option ME) is available with a 0 to 100% linear scale. The Smart Meter (option SM) provides an LCD display for both analog and digital output and can be configured to display pressure in pre-selected engineering units.</p> <p><b>HART<sup>®</sup> Protocol Compatibility (Options HC and H6)</b> Optional electronics modules for the ST 3000 provides HART Protocol compatibility in either HART 5.x or 6.x formats. Transmitters with a HART Option are compatible with any HART enabled system that provides 5.x or 6.x format support.</p> <p><b>FOUNDATION Fieldbus (Option FF)</b> Equips transmitter with FF protocol for use in 31.25 kbit/s FF networks. See document 34-ST-03-72 for additional information on ST 3000 Fieldbus transmitters.</p> <p><b>SIL2/SIL3 Certification (Option SL)</b> This ST 3000 product is available for use with safety systems. With the SL option, we are fully certified to SIL 2 capability for single transmitters and SIL 3 capability for multiple transmitter use through TÜV Nord Sys Tec GmbH &amp; Co. KG. We are in compliance with the following SIL standards: IEC 61508-1: 1998; IEC 61508-2: 2000; IEC 61508-3: 1998</p>	<p>Contact your nearest Honeywell sales office, or</p> <p>In the U.S.:</p> <p style="padding-left: 40px;">Honeywell Industrial Automation &amp; Control 16404 North Black Canyon Hwy. Phoenix, AZ 85053 1-800-288-7491</p> <p>In Canada:</p> <p style="padding-left: 40px;">The Honeywell Centre 155 Gordon Baker Rd. North York, Ontario M2H 3N7 1-800-461-0013</p> <p>In Latin America:</p> <p style="padding-left: 40px;">Honeywell Inc. 480 Sawgrass Corporate Parkway, Suite 200 Sunrise, FL 33325 (954) 845-2600</p> <p>In Europe and Africa:</p> <p style="padding-left: 40px;">Honeywell S. A. Avenue du Bourget 1 1140 Brussels, Belgium</p> <p>In Eastern Europe:</p> <p style="padding-left: 40px;">Honeywell Praha, s.r.o. Budejovicka 1 140 21 Prague 4, Czech Republic</p> <p>In the Middle East:</p> <p style="padding-left: 40px;">Honeywell Middle East Ltd. Khalifa Street, Sheikh Faisal Building Abu Dhabi, U. A. E.</p> <p>In Asia:</p> <p style="padding-left: 40px;">Honeywell Asia Pacific Inc. Honeywell Building, 17 Changi Business Park Central 1 Singapore 486073 Republic of Singapore</p> <p>In the Pacific:</p> <p style="padding-left: 40px;">Honeywell Pty Ltd. 5 Thomas Holt Drive North Ryde NSW Australia 2113 (61 2) 9353 7000</p> <p>In Japan:</p> <p style="padding-left: 40px;">Honeywell K.K. 14-6 Shibaura 1-chrome Minato-ku, Tokyo, Japan 105-0023</p> <p>Or, visit Honeywell on the World Wide Web at: <a href="http://www.honeywell.com">http://www.honeywell.com</a> Specifications are subject to change without notice</p>
<p><b>NAMUR NE43 Compliance (Option NE)</b> This option provides software the meets the NAMUR NE43 requirements for failsafe software. Transmitter failure information is generated when the measuring information is no longer valid. Transmitter failure values are: <math>\leq 3.6</math> mA and <math>\geq 21.0</math> mA. The normal ST 3000 ranges are <math>\leq 3.8</math> mA and <math>\geq 20.5</math> mA.</p> <p><b>Lightning Protection (Option LP)</b> A terminal block with circuitry that protects the transmitter from transient surges induced by nearby lightning strikes is available.</p> <p><b>Indicator Configuration (Option CI)</b> Provides custom configuration of Smart Meters</p> <p><b>Tagging (Option TG)</b> Up to 30 characters can be added on the stainless steel nameplate mounted on the transmitter's electronics housing at no extra cost. Note that a separate nameplate on the meter body contains the serial number and body-related data. A stainless steel wired on tag with additional data of up to 4 lines of 28 characters is also available. The number of characters for tagging includes spaces.</p> <p><b>Transmitter Configuration (Option TC)</b> The factory can configure the transmitter linear/square root extraction, damping time, LRV, URV and mode (analog/digital) and enter an ID tag of up to eight characters and scratchpad information as specified.</p> <p><b>Custom Calibration and ID in Memory (Option CC)</b> The factory can calibrate any range within the scope of the transmitter's range and enter an ID tag of up to eight characters in the transmitter's memory.</p>	

**Model Selection Guide (34-ST-16-32)**

**Instructions**

- Select the desired Key Number. The arrow to the right marks the selection available.
- Make one selection from each Table I and II using the column below the proper arrow.
- Select as many Table III options as desired (if no options or approvals are desired, specify 9X).
- A (\*) denotes unrestricted availability. A letter denotes restricted availability.
- Restrictions follow Table IV.

Key Number    I    II    III (Optional)    IV  
 [ ] - [ ] - [ ] - [ ] + [XXXX]

**KEY NUMBER**

Description	Selection	Availability		
0-10" to 0-400" H <sub>2</sub> O/0-25 to 0-1000 mbar Body Rating*: 2500 psi (172 bar) Compound Characterized	STR12D	↓		
0-5 to 0-100 psi/0-0.34 to 0-7 bar Body Rating*: 2500 psi (172 bar)	STR13D	↓		
0-5 to 0-500 psia/0-0.34 to 0-35 bar Body Rating*: 500 psi (35 bar)	STR14A		↓	
0-5 to 0-500 psi/0-0.34 bar to 0-35 bar Body Rating*: 500 psi (35 bar)	STR14G			↓
0-100 to 0-3000 psi/0-7 bar to 210 bar Body Rating*: 3000 psi (210 bar)	STR17G			↓

\* Remote seal system pressure rating is body rating or seal rating, whichever is less.

**TABLE I - METER BODY**

Number of Seals	1 Remote Seal (High Side)	1 __	•	•	•
	2 Remote Seals	2 __	•		
	1 Remote Seal (Low Side)	3 __	•		
	Value Added Model (VAM unit)	5 __	8	8	8
Fill Fluid (Meter body)	Silicone (DC 200)	_ 1 _	•	•	•
	CTFE	_ 2 _	q	q	q
<b>Construction</b>	<b>Non-Wetted Adapter Head Material</b>				
In-Line Gauge	316 SS Bonnet	_ _ A			•
	316 SS Bonnet for Close-Couple	_ _ D			y
Dual Head DP	316 SS (bolt-on heads)	_ _ A	•		
	316 SS for Close-Couple	_ _ D	y		
	316 SS with all-welded meter body	_ _ C	7		
Single Head Absolute	316 SS Adapter Head	_ _ A		•	
	316 SS Head for Close-Couple	_ _ D		y	

**TABLE II - SEALS**

Format for Seal Selection: Specify 12 characters								
<b>Note:</b> The first 3 characters are common to all seals. When selecting required seal, you must specify only the 9 selections within the required seal.				12D & 13D	14A	14G&17G		
				Selection				
Secondary Fill	No Fill Fluid			0 _____	3	3	3	
	Silicone (DC 200)			1 _____	•	•	•	
	CTFE			2 _____	•	•	•	
	Silicone (DC 704)			3 _____	p	p	p	
	Neobee(M20) **			4 _____	•	•	•	
	Syltherm 800 ***			5 _____	p	p	p	
Connection of Remote Seal to Meter Body	No Capillary, No Nipple			0 _____	3	3	3	
	Capillary Length	5 feet	1.5 m	SS Armor	A _____	•	•	•
		10 feet	3.0 m		B _____	•	•	•
		15 feet	4.5 m		C _____	•	•	•
		20 feet	6.1 m		D _____	•	•	•
		25 feet	7.5 m		E _____	•	•	•
		35 feet	10.7 m		F _____	•	•	•
	Capillary Length	5 feet	1.5 m	PVC Coated SS Armor	G _____	•	•	•
		10 feet	3.0 m		H _____	•	•	•
		15 feet	4.5 m		J _____	•	•	•
		20 feet	6.1 m		K _____	•	•	•
		25 feet	7.5 m		L _____	•	•	•
		35 feet	10.7 m		M _____	•	•	•
2 inch long SS nipple close-coupled				2 _____	z	z	z	
No Selection				0 _____	•	•	•	
No Seal Attached to Core Transmitter				0000000000	3	3	3	
Flush Flanged Seal	Diaphragm Diameter	Flange Size	Flange Pressure Rating *	Selection				
	3.5"	3"	ANSI Class 150	AFA _____	•	•	•	
			ANSI Class 300	AFC _____	•	•	•	
			DIN DN80-PN40	AFM _____	•	•	•	
	Wetted Material		Diaphragm	Upper Insert	Selection			
			316L SS	316 SS	AA _____	•	•	•
			Hastelloy C	316 SS	AB _____	•	•	•
			Hastelloy C	Hastelloy C	AC _____	•	•	•
			Monel	Monel	AE _____	•	•	•
	Tantalum	Tantalum <sup>a</sup>	AF _____	1	1	1		
Non-Wetted Material (upper)		CS (Nickel Plated)		1 _____	•	•	•	
		316 SS		2 _____	•	•	•	
Seal-Capillary Connection		Center Seal		1 _____	•	•	•	
		Side Seal		2 _____	9	9	9	
Calibration Rings		None		A _____	•	•	•	
		316 SS		B _____	5	5	5	
		Hastelloy C		C _____	5	5	5	
		Monel		D _____	5	5	5	

Table II continued next page

12D & 13D      14A      14G & 17G

**Selection**

	Flushing Connections and Plugs**** (Metal plug material will be the same as Cal. ring material if metal plug is chosen - SS Plug for CS Lower)	None One 1/4" with plastic plug One 1/4" with metal plug Two 1/4" with plastic plugs Two 1/4" with metal plugs One 1/2" with plastic plug One 1/2" with metal plug Two 1/2" with plastic plugs Two 1/2" with metal plugs	Selection			
			0 ----- H ----- J ----- M ----- N ----- P ----- Q ----- R ----- S	• 6 6 6 6 6 6 6 6 6 6 6	• 6 6 6 6 6 6 6 6 6 6 6	• 6 6 6 6 6 6 6 6 6 6 6
Flush Flanged Seal			0	•	•	•
			H	6	6	6
			J	6	6	6
			M	6	6	6
			N	6	6	6
			P	6	6	6
			Q	6	6	6
			R	6	6	6
			S	6	6	6

Table II continued below

- \* Standard facing 125-250 AARH RF (raised face) serrated surface finish.
- \*\* Limited vacuum availability.
- \*\*\* Minimum static pressure requirement. No vacuum allowed. See Specifications Figure 15.
- \*\*\*\* Plastic Plugs are TEMPORARY ONLY to protect threads and MUST be REMOVED before installation
- a Tantalum Upper insert has Tantalum wetted parts and 316 SS or CS non-wetted parts

**Note:** Remote seal system pressure rating is body rating or seal rating, whichever is less.

12D & 13D      14A      14G & 17G

**Selection**

	Diaphragm Diameter	Flange Size	Flange Pressure Rating *	Const. - See Spec. Figure 34-ST-03-64	Construction - See Spec. Figure 34-ST-03-64	Selection		
						t	4	•
Flush Flanged Seal with Lower	2.4"	1"	ANSI 150	22	--- BCA -----	t	4	•
			ANSI 300	22	--- BCC -----	t	4	•
		1-1/2"	ANSI 150	22	--- BGA -----	t	4	•
			ANSI 300	22	--- BGC -----	t	4	•
		2"	ANSI 150	22	--- BDA -----	t	4	•
			ANSI 300	22	--- BDC -----	t	4	•
		3"	ANSI 150	22	--- BFA -----	t	4	•
			ANSI 300	22	--- BFC -----	t	4	•
	2.9"	1/2"	ANSI 150	23	--- CAA -----	•	•	•
			ANSI 300	23	--- CCA -----	•	•	•
		1"	ANSI 150	23	--- CCC -----	•	•	•
			ANSI 300	23	--- CGA -----	•	•	•
		1-1/2"	ANSI 150	22	--- CGC -----	•	•	•
			ANSI 300	22	--- CDA -----	•	•	•
		2"	ANSI 150	22	--- CDC -----	•	•	•
			ANSI 300	22	--- DAA -----	•	•	•
	4.1"	1/2"	ANSI 150	22	--- DCA -----	•	•	•
			ANSI 300	23	--- DCC -----	•	•	•
		1"	ANSI 150	23	--- DGA -----	•	•	•
			ANSI 300	23	--- DGC -----	•	•	•
		1-1/2"	ANSI 150	23	--- DDA -----	•	•	•
			ANSI 300	22	--- DDC -----	•	•	•
		2"	ANSI 150	23	--- DFA -----	•	•	•
			ANSI 300	22	--- DFC -----	•	•	•

Table II continued next page

- \* Standard facing 125-250 AARH RF (raised face) serrated finish.
  - \*\* Plastic Plugs are TEMPORARY ONLY to protect threads and MUST be REMOVED before installation
- Note:** Remote seal system pressure rating is body rating or seal rating, whichever is less.

12D & 13D      ↓      ↓      ↓  
14A  
14G & 17G

**TABLE II - SEALS (continued)**

	Wetted Material	Diaphragm	Lower	Selection			
		316L SS	316 SS	----- BA -----	•	•	•
Hastelloy C	316 SS	----- BB -----	•	•	•		
Hastelloy C	Hastelloy C	----- BC -----	•	•	•		
Monel	Monel	----- BE -----	•	•	•		
Tantalum	316 SS	----- BF -----	1	1	1		
Tantalum	Hastelloy C	----- BG -----	1	1	1		
Tantalum	Tantalum Clad	----- BH -----	10	10	10		
Non-Wetted Material (upper, upper insert)	Upper	Upper Insert	Selection				
	316 SS	316 SS	----- 4 -----	•	•	•	
Carbon Steel	316 SS	----- 5 -----	•	•	•		
Bolts***	No Selection			----- 0 -----	•	•	•
Flushing Connections and Plugs** (Metal plug material will be the same as Lower material, if metal plug is chosen - (SS Plug for CS Lower and Tantalum Clad)	None			----- 0 -----	•	•	•
	One 1/4" with plastic plug			----- H -----	•	•	•
	One 1/4" with metal plug			----- J -----	•	•	•
	Two 1/4" with plastic plugs			----- M -----	•	•	•
	Two 1/4" with metal plugs			----- N -----	•	•	•
	One 1/2" with plastic plug			----- P -----	•	•	•
	One 1/2" with metal plug			----- Q -----	•	•	•
	Two 1/2" with plastic plugs			----- R -----	•	•	•
Two 1/2" with metal plugs			----- S -----	•	•	•	
Gasket	Klinger C-4401 (non-asbestos)			----- K -----	c	c	c
	Grafoil			----- G -----	•	•	•
	Teflon			----- T -----	c	c	c
	Gylon 3510			----- L -----	d	d	d
				----- 0 -----	•	•	•

\* Standard facing 125-250 AARH RF (raised face) serrated finish. Table II continued below  
 \*\* Plastic Plugs are TEMPORARY ONLY to protect threads and MUST be REMOVED before installation  
 \*\*\* Bolt material will be same as Upper Material. However, if Table III bolt/nut option is chosen, seal bolt material will be the same.  
**Note:** Remote seal system pressure rating is body rating or seal rating, whichever is less.

12D & 13D      ↓      ↓      ↓  
14A  
14G & 17G

**TABLE II - SEALS (continued)**

	Diaphragm Diameter	Flange Size	Flange Pressure Rating *	Selection				
Flange Seal with Extended Diaphragm	2.8"	3" (2.8" OD extension)	ANSI Class 150	----- EFA -----	•	•	•	
			ANSI Class 300	----- EFC -----	•	•	•	
			DIN DN80-PN40	----- EFM -----	•	•	•	
	3.5"	4" (3.70" OD extension)	ANSI Class 150	----- FGA -----	•	•	•	
			ANSI Class 300	----- FGC -----	•	•	•	
			DIN DN100-PN40	----- FGP -----	•	•	•	
	Wetted Material	Diaphragm	Ext. Tube	Selection				
		316L SS	316 SS	----- EA -----	•	•	•	
		Hastelloy C	316 SS	----- EB -----	•	•	•	
	Hastelloy C	Hastelloy C	----- EC -----	•	•	•		
	Non-Wetted Material (flange)	CS (Nickel Plated)		----- 7 -----	•	•	•	
		316 SS		----- 8 -----	•	•	•	
	Bolts	No Selection			----- 0 -----	•	•	•
	Extension Length	2"			----- 2 -----	•	•	•
		4"			----- 4 -----	•	•	•
6"			----- 6 -----	•	•	•		
No Selection	No Selection	No Selection	----- 0 -----	•	•	•		

Table II continued next page

TABLE II - SEALS (continued)

	Diaphragm Diameter	Flange Size	Flange Pressure Rating Dependent on Customer Flange		Selection	12D & 13D	14A	14G & 17G
			Diaphragm	Body				
Pancake Seal	3.5"	3"	ANSI Class 150/300/600		___ GFA ___	•	•	•
	Wetted Material		316L SS	316 SS	___ GA ___	•	•	•
			Hastelloy C	316 SS	___ GB ___	•	•	•
			Hastelloy C	Hastelloy C	___ GC ___	•	•	•
			Monel	Monel	___ GE ___	•	•	•
			Tantalum	Tantalum <sup>a</sup>	___ GG ___	1	1	1
	Non-Wetted Material		No Selection		___ 0 ___	•	•	•
	Bolts		No Selection		___ 0 ___	•	•	•
	Calibration Rings		None		___ A ___	•	•	•
			316 SS		___ B ___	5	5	5
			Hastelloy C		___ C ___	5	5	5
			Monel		___ D ___	5	5	5
	Flushing Connections and Plugs*** (Metal plug material will be the same as Cal. Ring material, if metal plug is chosen - SS Plug for CS Lower)		None		___ 0 ___	•	•	•
One 1/4" with plastic plug			___ H ___	6	6	6		
One 1/4" with metal plug			___ J ___	6	6	6		
Two 1/4" with plastic plugs			___ M ___	6	6	6		
Two 1/4" with metal plugs			___ N ___	6	6	6		
One 1/2" with plastic plug			___ P ___	6	6	6		
One 1/2" with metal plug			___ Q ___	6	6	6		
Two 1/2" with plastic plugs			___ R ___	6	6	6		
Two 1/2" with metal plugs		___ S ___	6	6	6			

Table II continued below

\* Standard facing 125-250 AARH RF (raised face) serrated finish.

\*\*\* Plastic Plugs are TEMPORARY ONLY to protect threads and MUST be REMOVED before installation

a Tantalum Body has Tantalum wetted parts and 316 SS non-wetted parts

Note: Remote seal system pressure rating is body rating or seal rating, whichever is less.

TABLE II - SEALS (continued)

	Diaphragm Diameter	Flange Size	Flange Pressure Rating *		Selection	12D & 13D	14A	14G & 17G
			Diaphragm	Body				
Chemical Tee "Taylor" Wedge	3.5"	Taylor Wedge 5" O.D.	750 psi		___ HM0 ___	v		
	Wetted Material		316L SS	316 SS	___ HA ___	•		
			Hastelloy C	316 SS	___ HB ___	•		
			Hastelloy C	Hastelloy C	___ HC ___	•		
	Non-Wetted Material		No Selection		___ 0 ___	•		
	Bolts		No Selection		___ 0 ___	•		
	Styles		No Selection		___ 0 ___	•		
No Selection		No Selection		___ 0 ___	•			

Table II continued next page

TABLE II - SEALS (continued)

Diaphragm Diameter	Threaded Process Connection Size (NPT Female)	Pressure Rating		Selection	12D & 13D	14A	14G & 17G	
		CS Bolts	304 SS Bolts					
Seal with Threaded Process Connection	2.4"	1/2" NPT	2500 psi	1250 psi	--- JJG ---	t	4	•
		3/4" NPT			--- JKG ---	t	4	•
		1" NPT			--- JLG ---	t	4	•
	2.9"	1/2" NPT	2500 psi	1250 psi	--- KJG ---	•	•	•
		3/4" NPT			--- KKG ---	•	•	•
		1" NPT			--- KLG ---	•	•	•
	4.1"	1/2" NPT	1500 psi	750 psi	--- LJG ---	•	•	•
		3/4" NPT			--- LKG ---	•	•	•
		1" NPT			--- LLG ---	•	•	•
Wetted Material	Diaphragm	Lower		Selection				
	316L SS	Carbon Steel		--- JA ---	•	•	•	
	316L SS	316 SS		--- JB ---	•	•	•	
	Hastelloy C	316 SS		--- JC ---	•	•	•	
	Hastelloy C	Hastelloy C		--- JD ---	•	•	•	
	Monel	Monel		--- JE ---	•	•	•	
	Tantalum	316 SS		--- JF ---	1	1	1	
Tantalum	Hastelloy C		--- JG ---	1	1	1		
Non-Wetted Material (upper)	CS (Nickel Plated)		--- A ---		•	•	•	
	Stainless Steel		--- C ---		w	w	w	
Bolts*	Carbon Steel		--- C ---		1	1	1	
	304 SS		--- D ---		•	•	•	
Flushing Connections and Plugs** (Metal plug material will be the same as Lower material, if metal plug is chosen - (SS Plug for CS Lower and Tantalum Clad)	None		--- 0 ---		•	•	•	
	One 1/4" with plastic plug		--- H ---		•	•	•	
	One 1/4" with metal plug		--- J ---		•	•	•	
	Two 1/4" with plastic plugs		--- M ---		•	•	•	
	Two 1/4" with metal plugs		--- N ---		•	•	•	
	One 1/2" with plastic plug		--- P ---		11	11	11	
One 1/2" with metal plug		--- Q ---		11	11	11		
Two 1/2" with plastic plugs		--- R ---		11	11	11		
Two 1/2" with metal plugs		--- S ---		11	11	11		
Gasket	Klinger C-4401 (non-asbestos)		--- K ---		c	c	c	
	Grafoil		--- G ---		•	•	•	
	Teflon		--- T ---		c	c	c	
	Gylon 3510		--- L ---		d	d	d	

Table II continued next page

\* If Table III Bolt/Nut option is chosen, Seal bolts will ship as same material, and MAWP may change.

\*\* Plastic Plugs are TEMPORARY ONLY to protect threads and MUST be REMOVED before installation

12D & 13D      14A      14G & 17G

TABLE II - SEALS (continued)

	Diaphragm Diameter	Flange Size	Pressure Rating		Selection			
	Sanitary Seal	1.9"	2"	Customer clamp rating or 600 psi, whichever is less		___ MDO ___		
2.4"		2-1/2"	___ NE0 ___			t		•
2.9"		3"	___ PF0 ___			•	•	•
4.1"		4"	___ QG0 ___			•	•	•
Wetted Material		<b>Diaphragm</b>	<b>Body</b>	<b>Selection</b>				
		316L SS	316 SS	___ N A ___	•	•	•	
Non-Wetted Material		No Selection		___ 0 ___	•	•	•	
Bolts		No Selection		___ 0 ___	•	•	•	
Styles		Tri-Clover Tri-Clamp		___ 8 ___	•	•	•	
Gasket		No Selection		___ 0 ___	•	•	•	
Saddle Seal	Diaphragm Diameter	Size and Bolt Pattern	Seal Pressure Rating **		Selection			
			C.S. Bolts	304 SS Bolts				
	2.4" 8-Bolt Design	for 3" Pipe ? 4" pipe	1500 psi	1500 psi	___ RFK ___	t	4	•
					___ RGK ___	t	4	•
	2.4" 6-Bolt Design	for 3" Pipe ? 4" pipe	1250 psi	1250 psi	___ RPK ___	t	4	•
					___ RQK ___	t	4	•
	Wetted Material		Diaphragm	Lower Housing	Selection			
			316L SS	Carbon Steel	___ RA ___	•	•	•
			316L SS	316 SS	___ RB ___	•	•	•
			Hastelloy C	316 SS	___ RC ___	•	•	•
			Hastelloy C	Hastelloy C	___ RD ___	•	•	•
			316L SS	N/A-Body Only	___ SB ___	•	•	•
	Hastelloy C	N/A-Body Only	___ SC ___	•	•	•		
	Non-Wetted Material		Body	Bolts *, ***	Selection			
Carbon Steel			Carbon Steel	___ B ___	1	1	1	
		316 SS	304 SS	___ C ___	•	•	•	
Bolts		No Selection		___ 0 ___	•	•	•	
Styles		No Selection		___ 0 ___	•	•	•	
Gasket		Klinger C-4401 (non-asbestos)		___ K ___	•	•	•	
		Grafoil		___ G ___	•	•	•	
		Teflon		___ T ___	•	•	•	
		Gylon 3510		___ L ___	•	•	•	

Note: All sanitary seals have dairy grade 3A approval.

Note: Remote seal system pressure rating is body rating or seal rating, whichever is less.

\* If a Table III Bolt/Nut option is chosen, Seal bolts will ship as same material, and MAWP may change.

	12D & 13D	14A	14G & 17G
None	00	•	•
<b>Communication Options</b>			
HART 5.x Protocol compatible electronics	H6	e	e
HART 6.x Protocol compatible electronics	HC	e	e
FOUNDATION Fieldbus Communications	FF	r	r
<b>Indicating Meter Options</b>			
Analog Meter (0-100 Even 0-10 Square Root)	ME	•	•
Smart Meter	SM	•	•
Custom Configuration of Smart Meter	CI	f	f
Local Zero & Span	ZS	m	m
Local Zero	LZ	x	x
<b>Transmitter Housing &amp; Electronics Options</b>			
NAMUR Failsafe Software	NE	15	15
SIL 2 - TÜV Certified transmitter (requires HC and WP options)	SL	14	14
Lightning Protection	LP	•	•
Custom Calibration and I.D. in Memory	CC	•	•
Transmitter Configuration - non-Fieldbus	TC	•	•
Write Protection (Delivered in the "enabled" position)	WP	•	•
Write Protection (Delivered in the "disabled" position)	WX	•	•
316 SS Electronics Housing - with M20 Conduit Connections	SH	n	n
1/2" NPT to M20 316 SS Conduit Adapter (BASEEFA EEx d IIC)	A1	n	n
1/2" NPT to 3/4" NPT 316 SS Conduit Adapter	A2	u	u
Stainless Steel Housing with M20 to 1/2" NPT 316 SS Conduit Adapter (use for FM and CSA Approvals)	A3	i	i
Stainless Steel Customer Wired-On Tag (4 lines, 28 characters per line, customer supplied information)	TG	•	•
Stainless Steel Customer Wired-On Tag (blank)	TB	•	•
End Cap Live Circuit Warning Label in Spanish (only with ATEX 3D)	SP	a	a
End Cap Live Circuit Warning Label in Portuguese (only with ATEX 3D)	PG	a	a
End Cap Live Circuit Warning Label in Italian (only with ATEX 3D)	TL	a	a
End Cap Live Circuit Warning Label in German (only with ATEX 3D)	GE	a	a
<b>Meter Body Options</b> (Seal bolt material depends on Transmitter bolt material)			
A286 SS (NACE) Bolts and 304 SS (NACE) Nuts for Heads	CR	•	•
316 SS Bolts and 316 SS Nuts for Process Heads	SS	•	•
B7M Bolts and Nuts for Process Heads	B7	•	•
<b>Remote Seal Options</b>			
Gold Plated Seal Diaphragm (1 Seal)	G1	j	j
Gold Plated Seal Diaphragm (2 Seals)	G2	j	j
Teflon Coated Seal Diaphragm (1 Seal) - only for anti-sticking	N1	j	j
Teflon Coated Seal Diaphragms(2 Seals) - only for anti-sticking	N2	j	j
<b>Transmitter Mounting Brackets Options</b>			
Mounting Bracket - Carbon Steel	MB	•	•
Mounting Bracket - 304 SS	SB	•	•
Flat Mounting Bracket	FB	•	•
<b>Services/Certificates Options</b>			
User's Manual Paper Copy (Standard, HC, or FF ships accordingly)	UM	•	•
Clean Transmitter for Oxygen or Chlorine Service with Certificate	OX	h	h
Over-Pressure Leak Test with F3392 Certificate	TP	•	•
Calibration Test Report and Certificate of Conformance (F3399)	F1	•	•
Certificate of Conformance (F3391)	F3	•	•
Certificate of Origin (F0195)	F5	•	•
FMEDA Certificate (SIL 1)	F6	•	•
NACE Certificate (F0198)	F7	o	o
NACE Certificate (F0198) for all welded meter bodies only	F8	16	•
Marine Type Approvals (DNV, ABS, BV & LR)	MT	2	2
<b>Warranty Options</b>			
Additional Warranty - 1 year	W1	•	•
Additional Warranty - 2 years	W2	•	•
Additional Warranty - 3 years	W3	•	•
Additional Warranty - 4 years	W4	•	•

12D & 13D → 14A ↓ 14G & 17G ↓

TABLE III - OPTIONS (continued)

Approval Body	Approval Type	Location or Classification	Selection			
No hazardous location approvals			9X	•	•	•
Factory Mutual	Explosion Proof	Class I, Div. 1, Groups A,B,C,D	1C	•	•	•
	Dust Ignition Proof	Class II, III Div. 1, Groups E,F,G				
	Non-Incendive	Class I, Div. 2, Groups A,B,C,D				
	Intrinsically Safe	Class I, II, III, Div. 1, Groups A,B,C,D,E,F,G				
CSA	Explosion Proof	Class I, Div. 1, Groups B,C,D	2J	•	•	•
	Dust Ignition Proof	Class II, III, Div. 1, Groups E,F,G				
	Intrinsically Safe	Class I, II, III, Div. 1, Groups A,B,C,D,E,F,G				
SA (Australia)	Intrinsically Safe	Ex ia IIC T4	4G	•	•	•
	Non-Sparking	Ex n IIC T6 (T4 with SM option)				
ATEX*	Intrinsically Safe, Zone 0/1	EEx ia IIC T4, T5, T6	3S	•	•	•
	Flameproof, Zone 1	EEx d IIC T5, T6, Enclosure IP 66/67	3D	•	•	•
	Non-Sparking, Zone 2	EEx nA, IIC T6 (Honeywell). Enclosure IP 66/67	3N	•	•	•
	Multiple Marking** Int. Safe, Zone 0/1, or Flameproof, Zone 1, or Non-Sparking, Zone 2	Ex II 1 G EEx ia IIC T4, T5, T6 Ex II 2 G EEx d IIC T5, T6 Ex II 3 G EEx nA, IIC T6 (Honeywell) Enclosure IP 66/67	3H	•	•	•
INMETRO (Brazil)	Flameproof, Zone 1	Ex d IIC T5	6D	•	•	•

\*See ATEX installation requirements in the ST 3000 User's Manual

\*\*The user must determine the type of protection required for installation of the equipment. The user shall then check the box adjacent to the type of protection used on the equipment certification nameplate. Once a type of protection has been check

TABLE IV

Factory Identification	XXXX	•	•	•
------------------------	------	---	---	---

**RESTRICTIONS**

Restriction Letter	Available Only With		Not Available With	
	Table	Selection	Table	Selection
a	III	3D or 3H		
b	Select only one option from this group			
c			II	----- BF ----- ----- BG ----- ----- JF ----- ----- JG -----
d	II	----- BF ----- ----- BG ----- ----- BH ----- ----- JF ----- ----- JG -----		
e			III	4G
f	III	SM		
h	I, II	_ 2 _ - 2 _		
i	III	1C or 2J		
j			II	----- AF ----- ----- BF ----- ----- BG ----- ----- BH ----- ----- GG ----- ----- JF ----- ----- JG -----
m			III	ME, FF
n			III	1C, 2J
o	III	CR		
p			II	DC704 and Syltherm 800 fills and close-couple require SS seal upper. --- CAA --- 5 --- --- CCA --- 5 --- --- CCC --- 5 --- --- DAA --- 5 --- --- DCA --- 5 --- --- DCC --- 5 --- --- DGA --- 5 --- --- DGC --- 5 --- --- DDA --- 5 --- ----- GE ----- ----- A ----- ----- B ----- --- BCA --- A ---
q	II	0 ----- 2 ----- 4 -----		
r			III	TC, ME, 4G, 3S
s	Must be specified with Model STR12D			

cont'd

RESTRICTIONS (continued)

Restriction Letter	Available Only With		Not Available With	
	Table	Selection	Table	Selection
t			I & II	2 _ _ _ B _ _ _ _ _ 2 _ _ _ C _ _ _ _ _ 2 _ _ _ D _ _ _ _ _ 2 _ _ _ E _ _ _ _ _ 2 _ _ _ F _ _ _ _ _ 2 _ _ _ H _ _ _ _ _ 2 _ _ _ J _ _ _ _ _ 2 _ _ _ K _ _ _ _ _ 2 _ _ _ L _ _ _ _ _ 2 _ _ _ M _ _ _ _ _
u	III	1C, 2J		
v	I	2 _ _		
w			II	_ _ _ _ _ JA _ _ _ _ _
x	III	FF, SM		
y			III	MB, SB, FB
			II	DC704 and Sytherm 800 fills and close-couple require SS seal upper. _ _ _ CAA _ _ 5 _ _ _ _ _ _ CCA _ _ 5 _ _ _ _ _ _ CCC _ _ 5 _ _ _ _ _ _ DAA _ _ 5 _ _ _ _ _ _ DCA _ _ 5 _ _ _ _ _ _ DCC _ _ 5 _ _ _ _ _ _ DGA _ _ 5 _ _ _ _ _ _ DGC _ _ 5 _ _ _ _ _ _ DDA _ _ 5 _ _ _ _ _ _ GE _ _ _ _ _ _ _ _ A _ _ _ _ _
			I	2
z	I	_ _ D	II	A - M
1			III	F7
2			III	FB
3	I	5 _ , 1 _		
4	II	See Figure 23 in Specification _ A _ _ _ _ _ _ G _ _ _ _ _ _ B _ _ _ _ _ _ H _ _ _ _ _ 2 _ _ _ _ _		
5			II	_ _ _ _ _ 0
6			II	_ _ _ _ _ A _
7			I	1 _ , 3 _
			III	CR
8			III	CC,G1,G2,T1,T2,OX,TP,MT,WP
9	II	_ _ _ _ _ AA2 _ _ _ _ _ _ _ _ AB2 _ _ _		
10	II	_ _ _ _ _ 0 _	II	_ _ _ _ _ T
			III	F7
11			II	_ _ _ J J G _ _ _ _ _ _ J K G _ _ _ _ _ _ J L G _ _ _ _ _ _ C A A _ _ _ _ _ _ C C A _ _ _ _ _ _ C C C _ _ _
14	III	HC, WP	III	FF, 00
15			III	FF
16	I	_ _ C		

**Note:** See ST-83 for Published Specials with pricing.  
See ST-89 and User's Manual for part numbers.  
See COMS Order Entry Information including TC, manuals, certificates, drawings and SPINS.  
See ST-OD-1 for tagging, ID, Transmitter Configuration (TC) and calibration including factory default values.  
To request a quote for a non-published "special", fax RFQ w/ Application Data Sht (34-ST-18-01) to Mktg. Applications.  
See Specification 34-ST-03-64 for Seal dimensions.

## Dimensions and Drawings

Type	Size	Non-Wetted Material	Wetted Materials		Construction See Figure	Dimension 3.5" Diaphragm Dia. (in.)	
			Diaphragm	Upper Insert		A	B
Flush Flanged Seal	3" 150	CS	All	All	21a	7.50	1.08
		SS	316L SS	N/A	21b	7.50	0.94
			Hast C	SS	21b		0.94
			Hast C	Hast C	21a		1.08
			Monel	Monel	21a		1.08
	Tantalum	Tantalum	21a	1.08			
	3" 300	CS	All	All	21a	8.25	1.26
		SS	316L SS	N/A	21b	8.25	1.12
			Hast C	SS	21b		1.12
			Hast C	Hast C	21a		1.26
	Monel		Monel	21a	1.26		
	Tantalum	Tantalum	21a	1.26			
	3" 600	CS	All	All	21a	8.25	1.50
		SS	316L SS	N/A	21b	8.25	1.50
Hast C			SS	21b	1.50		
Hast C			Hast C	21a	1.50		
Monel			Monel	21a	1.50		
Tantalum	Tantalum	21a	1.50				
DN80- PN40	CS	All	All	21a	7.87	1.02	
	SS	316L SS	N/A	21b	7.87	0.94	
		Hast C	SS	21b		0.94	
Hast C		Hast C	21a	1.02			
Monel	Monel	21a	1.02				
Tantalum	Tantalum	21a	1.02				

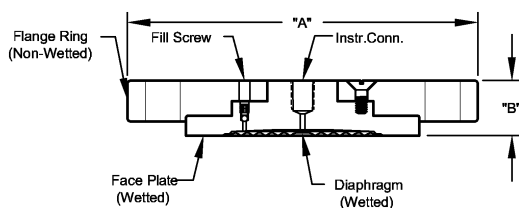

Figure 21a. Flush Flanged Seal

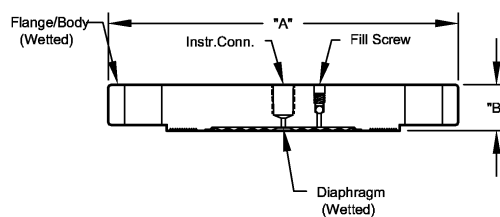

Figure 21b. Flush Flanged Seal

Dimensions and Drawings, cont.

Type	Size	Dim.	2.4" Diaph. Dia. (in.)	2.9" Diaph. Dia. (in.)	4.1" Diaph. Dia. (in.)	
Flush Flanged Seal With Lower	150#	1/2"	A	□ 3.50	□ 4.00	□ 5.25
			B0	□ 1.72	□ 1.72	□ 1.84
			B1	□ 1.72	□ 1.72	□ 1.84
			B2	□ 2.22	□ 2.22	□ 2.34
		1"	A	○ 4.25	□ 4.00	□ 5.25
	B0	○ 1.12	□ 1.72	□ 1.84		
	B1	○ 1.62	□ 1.72	□ 1.84		
	B2	○ 1.98	□ 2.22	□ 2.34		
	1-1/2"	A	○ 5.00	○ 5.00	□ 5.25	
	B0	○ 1.17	○ 1.72	□ 1.78		
	B1	○ 1.67	○ 1.72	□ 2.12		
	B2	○ 2.02	○ 2.22	□ 2.12		
	2"	A	○ 6.00	○ 6.00	□ 6.00	
	B0	○ 1.34	○ 1.34	□ 2.12		
	B1	○ 1.84	○ 1.84	□ 2.12		
	B2	○ 2.34	○ 2.34	□ 2.12		
	3"	A	○ 7.50	○ 7.50	○ 7.50	
	B0	○ 1.53	○ 1.53	○ 1.63		
	B1	○ 2.03	○ 2.03	○ 2.03		
	B2	○ 2.53	○ 2.53	○ 2.43		
300#	1"	A	○ 4.88	□ 4.00	□ 5.25	
		B0	○ 1.27	□ 1.72	□ 1.88	
		B1	○ 1.77	□ 1.72	□ 2.12	
		B2	○ 2.27	□ 2.22	□ 2.12	
	1-1/2"	A	○ 6.12	○ 6.12	□ 5.25	
B0	○ 1.40	○ 1.40	□ 2.12			
B1	○ 1.90	○ 1.96	□ 2.12			
B2	○ 2.40	○ 2.46	□ 2.12			
2"	A	○ 6.50	○ 6.50	○ 6.50		
B0	○ 1.47	○ 1.47	○ 1.67			
B1	○ 1.97	○ 1.97	○ 2.17			
B2	○ 2.47	○ 2.47	○ 2.47			
3"	A	○ 8.25	○ 8.25	○ 8.25		
B0	○ 2.09	○ 2.09	○ 1.81			
B1	○ 2.21	○ 2.21	○ 2.21			
B2	○ 2.61	○ 2.61	○ 2.61			
600#	1"	A	○ 4.88	□ 4.50	□ 5.25	
		B0	○ 1.84	□ 2.15	□ 2.26	
		B1	○ 1.84	□ 2.15	□ 2.26	
		B2	○ 2.34	□ 2.40	□ 2.50	
	1-1/2"	A	○ 6.12	○ 6.12	□ 5.25	
B0	○ 1.78	○ 1.53	○ 2.39			
B1	○ 2.03	○ 2.09	○ 2.39			
B2	○ 2.53	○ 2.49	○ 2.50			
2"	A	○ 6.50	○ 6.50	○ 6.50		
B0	○ 1.65	○ 1.65	○ 1.85			
B1	○ 2.15	○ 2.15	○ 2.25			
B2	○ 2.65	○ 2.65	○ 2.63			
3"	A	○ 8.25	○ 8.25	○ 8.25		
B0	○ 2.28	○ 2.28	○ 2.28			
B1	○ 2.40	○ 2.40	○ 2.40			
B2	○ 2.80	○ 2.80	○ 2.80			

B0 = Without Flush  
B1 = B Dimension With 1/4 NPT Flush  
B2 = B Dimension With 1/2 NPT Flush

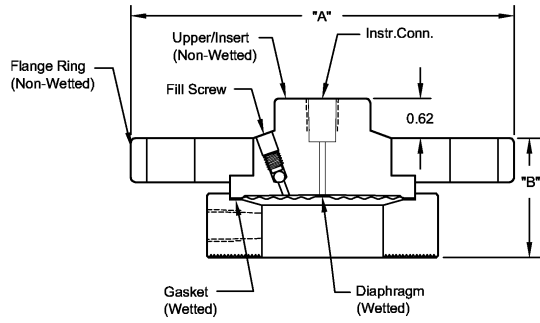

Figure 22 Flush Flanged Seal with Lower

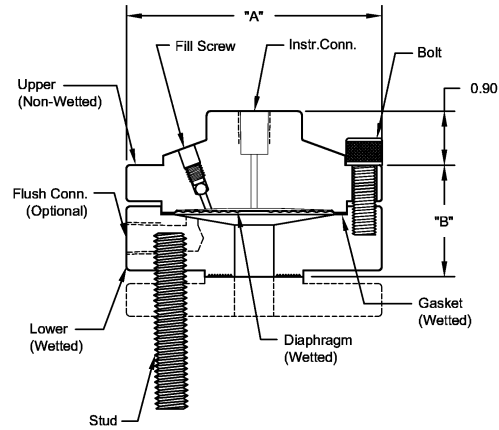

Figure 23 Flush Flanged Seal with Lower

Note: 0.90 Dimension is 0.70 for 4.1 Dia. Diaphragm

Dimensions and Drawings, cont.

Type	Size	Dim.	2.8" Diaph. Dia. (in.)	3.5" Diaph. Dia. (in.)
Flanged Seal With Extended Diaphragm	3" 150	A	7.50	-
		B	0.94	-
		C	2.80	-
	3" 300	A	8.25	-
		B	1.12	-
		C	2.80	-
	DIN DN80-PN40	A	7.87	-
		B	0.94	-
		C	2.80	-
	4" 150	A	-	9.00
		B	-	0.94
		C	-	3.70
4" 300	A	-	10.00	
	B	-	1.25	
	C	-	3.70	
DIN DN100-PN40	A	-	9.25	
	B	-	0.94	
	C	-	3.70	

\* Designed to mate with Sch 40 pipe

Type	Size	Dimension	3.5" Diaph. Dia. (in.)
Pancake Seal	150/300/600	A	5.00
		B	1.08

Type	Size	Dimension	3.5" Diaph. Dia. (in.)
Chemical Tee "Taylor Wedge" Seal	750 psi	A	5.00
		B	0.50

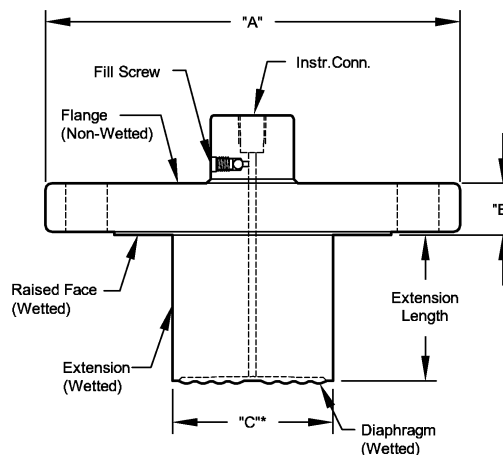

Figure 24 Flange Extended Seal

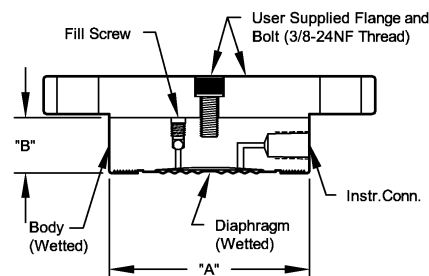

Figure 25 Pancake Seal

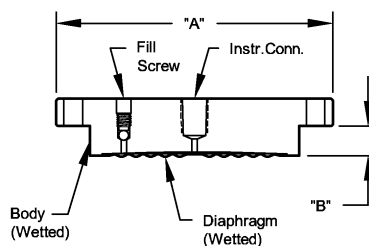

Figure 26 Chemical Tee "Taylor Wedge" Seal

Dimensions and Drawings, cont.

Type	Size	Dim.	2.4" Diaph. Dia. (in.)	2.9" Diaph. Dia. (in.)	4.1" Diaph. Dia. (in.)
Seal With Threaded Process Connection	1/4" or 1/2"	A	3.50	4.00	5.25
		B0	1.66	1.66	1.79
		B1	1.66	1.66	1.79
	3/4" or 1"	A	3.50	4.00	5.25
		B0	1.66	1.66	1.79
		B2	2.16	2.16	2.14

B0 = B dimension for No Flush  
B1 = B dimension for 1/4 NPT  
B2 = B dimension for 1/2 NPT

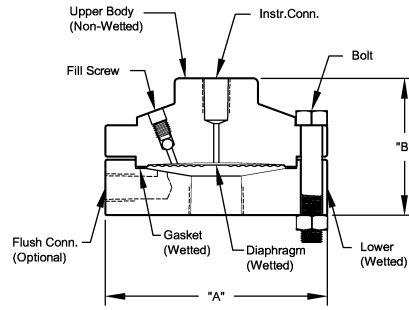

Figure 27 Threaded Process Connection

Type	Size	Dim.	1.9" Diaph. Dia. (in.)	2.4" Diaph. Dia. (in.)	2.9" Diaph. Dia. (in.)	4.1" Diaph. Dia. (in.)
Sanitary Seal	2"	A	2.50	-	-	-
		B	1.42	-	-	-
	2-1/2"	A	-	3.00	-	-
		B	-	1.28	-	-
	3"	A	-	-	3.57	-
		B	-	-	1.38	-
4"	A	-	-	-	4.68	
	B	-	-	-	1.60	

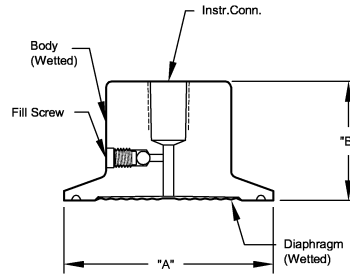

Figure 28 Sanitary Seal

Dimensions and Drawings, cont.

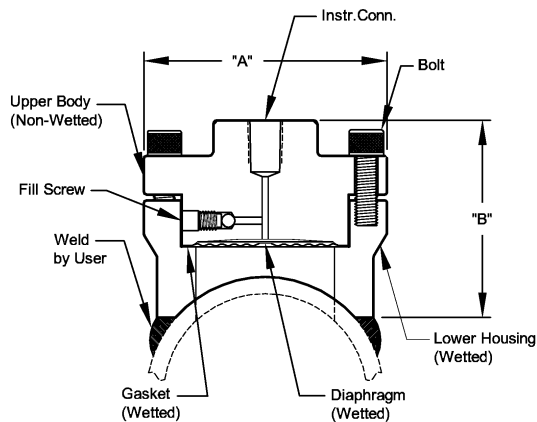

Figure 29 3" Saddle Seal

Type	Size	Dimension	2.4" Diaph. Dia.
Saddle Seal	3"	A	3.50
		B	2.90
	4" or larger	A	3.50
		B	3.04

Note: Specify 6 or 8 Bolt Pattern

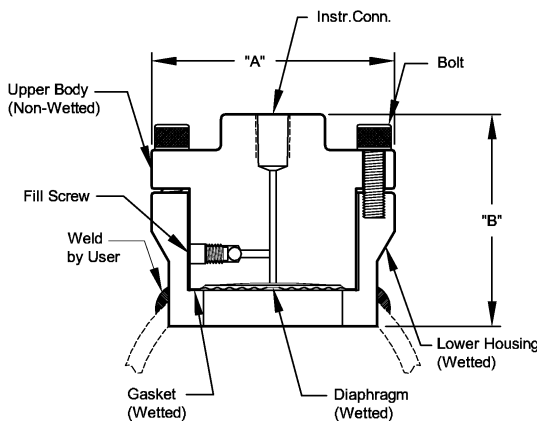

Figure 30 4" or larger Saddle Seal

SIZE	RATING	DIM.	1/4 NPT	1/2 NPT
3"	150/600#	A	5.00	5.00
		B	1.00	1.50
		C	3.00	3.00

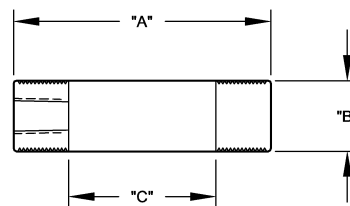

Figure 31 Calibration Ring

**THIS PAGE INTENTIONALLY BLANK**

ST 3000® is a registered trademark of Honeywell International Inc.  
HART\* is a trademark of the Hart Communication Foundation.  
FOUNDATION™ is a trademark of the Fieldbus Foundation.

**Honeywell**

---

**Honeywell Process Solutions**  
**Industrial Measurement and Control**  
Honeywell International Inc.  
2500 W. Union Hill Drive  
Phoenix, Arizona 85027

©Honeywell International Inc.