

ST 3000 Smart Transmitter Series 100 Flange Mounted Liquid Level Models

STF128	0 to 400 inH ₂ O	0 to 1000 mbar
STF132	0 to 100 psi	0 to 7 bar
STF12F	0 to 400 inH ₂ O	0 to 1000 mbar
STF13F	0 to 100 psi	0 to 7 bar
STF14F	0 to 600 inH ₂ O	0 to 1500 mbar

Specification and Model Selection Guide

Introduction

In 1983, Honeywell introduced the first Smart Pressure Transmitter—the ST 3000®. In 1989, Honeywell launched the first all digital, bi-directional protocol for smart field devices. Today, its ST 3000 Series 100 Flange-mount Transmitters continue to bring proven “smart” technology to a wide spectrum of measurement applications.

Honeywell flange-mount transmitters may be installed directly onto a tank flange and are offered with a variety of tank connections to include ANSI flange connections. Typical applications are high accuracy level measurement in pressurized and unpressurized vessels in the chemical and hydrocarbon industries. Honeywell flange mount transmitters demonstrate proven reliability in hundreds on installations in a wide variety of industries and applications.

All ST 3000 transmitters can provide a 4-20 mA output, Honeywell Digitally Enhanced (DE) output, HART* output, or FOUNDATION™ Fieldbus output.

When digitally integrated with Honeywell’s Process Knowledge System™, EXPERION PKS™, ST 3000 instruments provide a more accurate process variable as well as advanced diagnostics.

Honeywell’s high-performance ST 3000 S100 transmitters lead the industry in:

- Accuracy
- Stability
- Reliability
- Rangeability
- Warranty

Includes Lifetime™ Transmitters:

- Total Accuracy = $\pm 0.0375\%$
- Stability = $\pm 0.01\%$ per year
- Reliability = 470 years MTBF
- Rangeability = 400 to 1
- Lifetime Warranty = 15 years



Figure 1—Series 100 Flange Mounted Liquid Level Pressure Transmitters feature proven piezoresistive sensor technology.

The devices provide comprehensive self-diagnostics to help users maintain high uptime, meet regulatory requirements, and attain high quality standards. S100 transmitters are ideal for critical applications, such as custody transfer of natural gas and energy and material balances, where accuracy and stability are of the utmost importance.

"Our commitment to Honeywell field instruments is based on seamless integration with our Honeywell system and the enhanced fault detection that the Honeywell DE protocol offers. Honeywell instruments also offer us a better way of ensuring database integrity over simple analog instruments. In addition, Honeywell's high-quality support has enabled us to better implement solutions to some of our more difficult problems. We have used Honeywell differential pressure smart transmitters for the past eight years. Based on their accuracy and low failure rates, we are now targeting critical flow applications that require the robustness that these transmitters bring."

DCS Systems Engineer
International Integrated Oil Company

Description

The ST 3000 transmitter can replace any 4 to 20 mA output transmitter in use today and operates over a standard two-wire system.

The measuring means is a piezoresistive sensor, which actually contains three sensors in one. It contains a differential pressure sensor, a temperature sensor, and a static pressure sensor.

Microprocessor-based electronics provide higher span-turndown ratio, improved temperature and pressure compensation, and improved accuracy.

The transmitter's meter body and electronics housing resist shock, vibration, corrosion, and moisture. The electronics housing contains a compartment for the single-board electronics, which is isolated from an integral junction box. The single-board electronics is replaceable and interchangeable with any other ST 3000 Series 100 or Series 900 model transmitter.

Like other Honeywell transmitters, the ST 3000 features two-way communication and configuration capability between the operator and the transmitter through several Honeywell field-rated portable configuration devices, including the Smart Field Communicator (SFC) and the Multiple Communication Configurator (MC ToolKit). While both are made for in-field use, the MC Toolkit also can be ordered for use in intrinsically safe environments.

The SCT 3000 Smartline[®] Configuration Toolkit provides an easy way to configure instruments using a personal computer. The toolkit enables configuration of devices before shipping or installation. The SCT 3000 can operate in the offline mode to configure an unlimited number of devices. The database can then be loaded down-line during commissioning.

Features

- Choice of linear or square root output conformity is a simple configuration selection.
- Direct digital integration with Experion PKS and other control systems provides local measurement accuracy to the system level without adding typical A/D and D/A converter inaccuracies.
- Unique piezoresistive sensor automatically compensates input for temperature and static pressure. Added "smart" features include configuring lower and upper range values, simulating accurate analog output, and selecting preprogrammed engineering units for display.
- Smart transmitter capabilities with local or remote interfacing means significant manpower efficiency improvements in commissioning, start-up, and ongoing maintenance functions.

Specifications

Operating Conditions – All Models

Parameter	Reference Condition		Rated Condition		Operative Limits		Transportation and Storage	
	°C	°F	°C	°F	°C	°F	°C	°F
Ambient Temperature All models except STF14F STF14F	25±1	77±2	-40 to 85	-40 to 185	-40 to 93	-40 to 200	-55 to 125	-67 to 257
	25±1	77±2	-40 to 85	-40 to 185	-40 to 85	-40 to 185	-55 to 125	-67 to 257
Meter Body Temperature All models except STF14F STF14F	25±1	77±2	-40 to 110*	-40 to 230*	-40 to 125	-40 to 257	-55 to 125	-67 to 257
	25±1	77±2	-40 to 85	-40 to 185	-40 to 85	-40 to 185	-55 to 125	-67 to 257
Process Interface Temp. STF128, STF132 only	25±1	77±2	-40 to 110*	-40 to 230*	-40 to 175**	-40 to 350**	-55 to 125	-67 to 257
Humidity %RH	10 to 55		0 to 100		0 to 100		0 to 100	
Minimum Pressure mmHg absolute inH ₂ O absolute	atmospheric atmospheric		25 13		2 (short term ***) 1 (short term ***)			
Supply Voltage, Current, and Load Resistance	Voltage Range: 10.8 to 42.4 Vdc at terminals Current Range: 3.0 to 21.8 mA Load Resistance: 0 to 1440 ohms (as shown in Figure 2)							

* For CTFE fill fluid, the rating is -15 to 110 °C (5 to 230°F)

** For CTFE fill fluid, the maximum temperature rating is 150°C (300°F)

*** Short term equals 2 hours at 70°C (158 °F)

Maximum Allowable Working Pressure (MAWP)

STF 128, STF 132	Flange Material	Ambient Temperature -29 to 38 C [-20 to 100 F]	Maximum Meterbody Temperature 125 C [257 F]	Process Interface Temperature 175 C [350 F]
ANSI Class 150 psi [bar]	Carbon Steel	285 [19.6]	245 [16.9]	215 [14.8]
	304 S.S.	275 [19.0]	218 [15.0]	198 [13.7]
	316 S.S.	275 [19.0]	225 [15.5]	205 [14.1]
ANSI Class 300 psi [bar]	Carbon Steel	740 [51.0]	668 [46.0]	645 [44.5]
	304 S.S.	720 [49.6]	570 [39.3]	518 [35.7]
	316 S.S.	720 [49.6]	590 [40.7]	538 [37.1]
DN PN40 psi [bar]	Carbon Steel	580 [40.0] (1)	574 [39.6]	559 [38.5]
	304 S.S.	534 [36.8] (1)	419 [28.9]	385 [26.5]
	316 S.S.	534 [36.8] (1)	434 [29.9]	399 [27.5]
STF12F, STF13F, STF14F ANSI Class 150 psi [bar]	316L Stainless Steel	230 [15.9]	185 [12.8]	No rating at this temp

(1) Ambient Temperature for DN PN40 is -10 to 50 C [14 to 122 F]

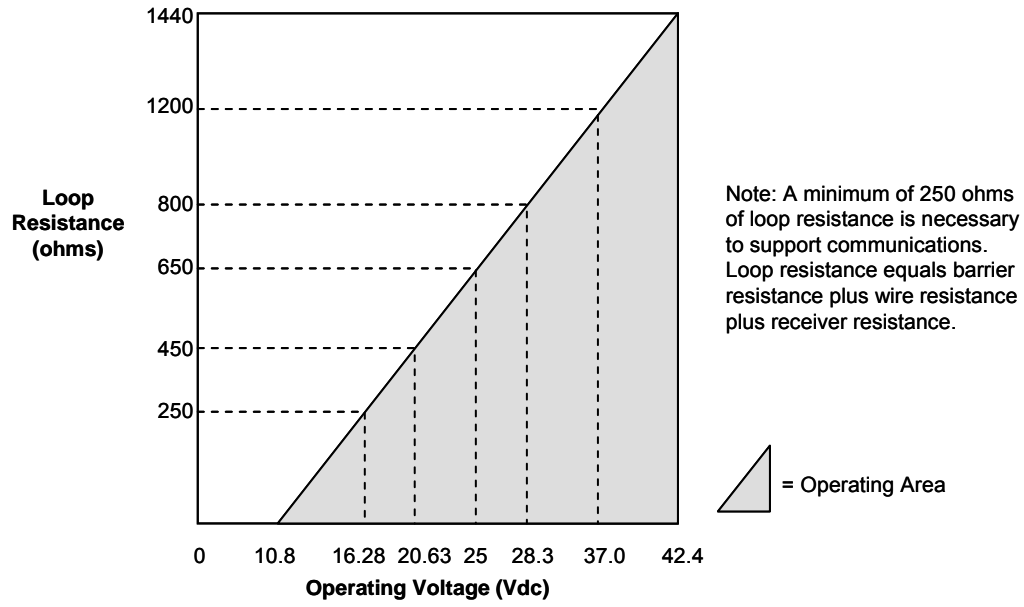

Figure 2 – Supply voltage and loop resistance chart.

Performance Under Rated Conditions* - Model STF128 (0 to 400 inH₂O)

Parameter	Description
Upper Range Limit inH ₂ O mbar	400 (39.2°F/4°C is standard reference temperature for inH ₂ O range.) 1000
Minimum Span inH ₂ O mbar	10 25
Turndown Ratio	40 to 1
Zero Elevation and Suppression	No limit except minimum span within ±100% URL. Specifications valid from –100% to + 100% URL.
Accuracy (Reference – Includes combined effects of linearity, hysteresis, and repeatability) • Accuracy includes residual error after averaging successive readings. • For FOUNDATION Fieldbus use Digital Mode specifications. For HART use Analog Mode specifications.	In Analog Mode: ±0.10% of calibrated span or upper range value (URV), whichever is greater, terminal based. For URV calibrated below reference point (25 inH ₂ O), accuracy equals: $\pm 0.05 + 0.05 \left(\frac{25 \text{ inH}_2\text{O}}{\text{span psi}} \right)$ or $\pm 0.05 + 0.05 \left(\frac{62.5 \text{ mbar}}{\text{span mbar}} \right)$ in % of span In Digital Mode: ±0.075% of calibrated span or upper range value (URV), whichever is greater, terminal based. For URV calibrated below reference point (25 inH ₂ O), accuracy equals: $\pm 0.025 + 0.05 \left(\frac{25 \text{ inH}_2\text{O}}{\text{span psi}} \right)$ or $\pm 0.025 + 0.05 \left(\frac{62.5 \text{ mbar}}{\text{span mbar}} \right)$ in % of span
Zero Temperature Effect per 28°C (50°F)	In Analog Mode: ±0.2125% of span. For URV below reference point (50 inH ₂ O), effect equals: $\pm 0.0125 + 0.20 \left(\frac{50 \text{ inH}_2\text{O}}{\text{span inH}_2\text{O}} \right)$ or $\pm 0.0125 + 0.20 \left(\frac{125 \text{ mbar}}{\text{span mbar}} \right)$ in % of span In Digital Mode: ±0.20% of span. For URV below reference point (50 inH ₂ O), effect equals: $\pm 0.20 \left(\frac{50 \text{ inH}_2\text{O}}{\text{span inH}_2\text{O}} \right)$ or $\pm 0.20 \left(\frac{125 \text{ mbar}}{\text{span mbar}} \right)$ in % of span
Combined Zero and Span Temperature Effect per 28°C (50°F)	In Analog Mode: ±0.40% of span. For URV below reference point (50 inH ₂ O), effect equals: $\pm 0.20 + 0.20 \left(\frac{50 \text{ inH}_2\text{O}}{\text{span inH}_2\text{O}} \right)$ or $\pm 0.20 + 0.20 \left(\frac{125 \text{ mbar}}{\text{span mbar}} \right)$ in % of span In Digital Mode: ±0.375% of span. For URV below reference point (50 inH ₂ O), effect equals: $\pm 0.175 + 0.20 \left(\frac{50 \text{ inH}_2\text{O}}{\text{span inH}_2\text{O}} \right)$ or $\pm 0.175 + 0.20 \left(\frac{125 \text{ mbar}}{\text{span mbar}} \right)$ in % of span

* Performance specifications are based on reference conditions of 25°C (77°F), zero (0) static pressure, 10 to 55% RH, and 316 Stainless Steel barrier diaphragm.

Table continued on next page ⇒

Performance Under Rated Conditions* - Model STF128 (0 to 400 inH₂O), continued

Parameter	Description
Zero Static Pressure Effect per 300 psi (20 bar)	±0.1625% of span. For URV below reference point (50 inH ₂ O), effect equals: $\pm 0.0125 + 0.15 \left(\frac{50 \text{ inH}_2\text{O}}{\text{span inH}_2\text{O}} \right)$ or $\pm 0.0125 + 0.15 \left(\frac{125 \text{ mbar}}{\text{span mbar}} \right)$ in % of span
Combined Zero and Span Static Pressure Effect per 300 psi (20 bar)	±0.30% of span. For URV below reference point (50 inH ₂ O), effect equals: $\pm 0.15 + 0.15 \left(\frac{50 \text{ inH}_2\text{O}}{\text{span inH}_2\text{O}} \right)$ or $\pm 0.15 + 0.15 \left(\frac{125 \text{ mbar}}{\text{span mbar}} \right)$ in % of span
Stability	±0.03% of URL per year

Performance Under Rated Conditions* - Model STF132 (0 to 100 psi)

Parameter	Description
Upper Range Limit psi bar	100 7
Minimum Span psi bar	5 0.35
Turndown Ratio	20 to 1
Zero Elevation and Suppression	No limit except minimum span within ±100% URL. Specifications valid from –100% to + 100% URL.
Accuracy (Reference – Includes combined effects of linearity, hysteresis, and repeatability) • Accuracy includes residual error after averaging successive readings. • For FOUNDATION Fieldbus use Digital Mode specifications. For HART use Analog Mode specifications.	In Analog Mode: ±0.10% of calibrated span or upper range value (URV), whichever is greater, terminal based. For URV calibrated below reference point (20 psi), accuracy equals: $\pm 0.05 + 0.05 \left(\frac{20 \text{ psi}}{\text{span psi}} \right)$ or $\pm 0.05 + 0.05 \left(\frac{1.4 \text{ bar}}{\text{span bar}} \right)$ in % of span In Digital Mode: ±0.075% of calibrated span or upper range value (URV), whichever is greater, terminal based. For URV calibrated below reference point (20 psi), accuracy equals: $\pm 0.025 + 0.05 \left(\frac{20 \text{ psi}}{\text{span psi}} \right)$ or $\pm 0.025 + 0.05 \left(\frac{1.4 \text{ bar}}{\text{span bar}} \right)$ in % of span
Zero Temperature Effect per 28°C (50°F)	In Analog Mode: ±0.2125% of span. For URV below reference point (30 psi), effect equals: $\pm 0.0125 + 0.20 \left(\frac{30 \text{ psi}}{\text{span psi}} \right)$ or $\pm 0.0125 + 0.20 \left(\frac{2 \text{ bar}}{\text{span bar}} \right)$ in % of span In Digital Mode: ±0.20% of span. For URV below reference point (30 psi), effect equals: $\pm 0.20 \left(\frac{30 \text{ psi}}{\text{span psi}} \right)$ or $\pm 0.20 \left(\frac{2 \text{ bar}}{\text{span bar}} \right)$ in % of span

* Performance specifications are based on reference conditions of 25°C (77°F), zero (0) static pressure, 10 to 55% RH, and 316 Stainless Steel barrier diaphragm.

Table continued on next page ⇒

Performance Under Rated Conditions* - Model STF132 (0 to 100 psi), continued

Parameter	Description
Combined Zero and Span Temperature Effect per 28°C (50°F)	<p>In Analog Mode: ±0.40% of span. For URV below reference point (30 psi), effect equals: $\pm 0.20 + 0.20 \left(\frac{30 \text{ psi}}{\text{span psi}} \right)$ or $\pm 0.20 + 0.20 \left(\frac{2 \text{ bar}}{\text{span bar}} \right)$ in % of span</p> <p>In Digital Mode: ±0.375% of span. For URV below reference point (30 psi), effect equals: $\pm 0.175 + 0.20 \left(\frac{30 \text{ psi}}{\text{span psi}} \right)$ or $\pm 0.175 + 0.20 \left(\frac{2 \text{ bar}}{\text{span bar}} \right)$ in % of span</p>
Zero Static Pressure Effect per 300 psi (20 bar)	<p>±0.1625% of span. For URV below reference point (30 psi), effect equals: $\pm 0.0125 + 0.15 \left(\frac{30 \text{ psi}}{\text{span psi}} \right)$ or $\pm 0.0125 + 0.15 \left(\frac{2 \text{ bar}}{\text{span bar}} \right)$ in % of span</p>
Combined Zero and Span Static Pressure Effect per 300 psi (20 bar)	<p>±0.30% of span. For URV below reference point (30 psi), effect equals: $\pm 0.15 + 0.15 \left(\frac{30 \text{ psi}}{\text{span psi}} \right)$ or $\pm 0.15 + 0.15 \left(\frac{2 \text{ bar}}{\text{span bar}} \right)$ in % of span</p>
Stability	±0.04% of URL per year

Performance Under Rated Conditions* - Model STF12F (0 to 400 inH₂O)

Parameter	Description
Upper Range Limit inH ₂ O mbar	400 (39.2°F/4°C is standard reference temperature for inH ₂ O range.) 25
Minimum Span inH ₂ O mbar	1 Note: Recommended minimum span in square root mode is 20 inH ₂ O (50 mbar). 2.5
Turndown Ratio	400 to 1
Zero Elevation and Suppression	No limit except minimum span within ±100% URL. Specifications valid from -5 to +100% URL.
<p>Accuracy (Reference – Includes combined effects of linearity, hysteresis, and repeatability)</p> <ul style="list-style-type: none"> Accuracy includes residual error after averaging successive readings. For FOUNDATION Fieldbus use Digital Mode specifications. For HART use Analog Mode specifications. 	<p>In Analog Mode: ±0.075% of calibrated span or upper range value (URV), whichever is greater, terminal based. For URV below reference point (25 inH₂O), accuracy equals: $\pm 0.025 + 0.05 \left(\frac{25 \text{ inH}_2\text{O}}{\text{span inH}_2\text{O}} \right)$ or $\pm 0.025 + 0.05 \left(\frac{62 \text{ mbar}}{\text{span mbar}} \right)$ in % of span</p> <p>In Digital Mode: ±0.0625% of calibrated span or upper range value (URV), whichever is greater, terminal based. For URV below reference point (25 inH₂O), accuracy equals: $\pm 0.0125 + 0.05 \left(\frac{25 \text{ inH}_2\text{O}}{\text{span inH}_2\text{O}} \right)$ or $\pm 0.0125 + 0.05 \left(\frac{62 \text{ mbar}}{\text{span mbar}} \right)$ in % of span</p>

* Performance specifications are based on reference conditions of 25°C (77°F), zero (0) static pressure, 10 to 55% RH, and 316 Stainless Steel barrier diaphragm.

Table continued on next page ⇒

Performance Under Rated Conditions* - Model STF12F (0 to 400 inH₂O), continued

Parameter	Description
Zero Temperature Effect per 28°C (50°F)	<p>In Analog Mode: ±0.0625% of span. For URV below reference point (50 inH₂O), effect equals: $\pm 0.0125 + 0.05 \left(\frac{50 \text{ inH}_2\text{O}}{\text{span inH}_2\text{O}} \right) \text{ or } \pm 0.0125 + 0.05 \left(\frac{125 \text{ mbar}}{\text{span mbar}} \right) \text{ in \% of span}$</p> <p>In Digital Mode: ±0.05% of span. For URV below reference point (50 inH₂O), effect equals: $\pm 0.05 \left(\frac{50 \text{ inH}_2\text{O}}{\text{span inH}_2\text{O}} \right) \text{ or } \pm 0.05 \left(\frac{125 \text{ mbar}}{\text{span mbar}} \right) \text{ in \% of span}$</p>
Combined Zero and Span Temperature Effect per 28°C (50°F)	<p>In Analog Mode: ±0.10% of span. For URV below reference point (50 inH₂O), effect equals: $\pm 0.05 + 0.05 \left(\frac{50 \text{ inH}_2\text{O}}{\text{span inH}_2\text{O}} \right) \text{ or } \pm 0.05 + 0.05 \left(\frac{125 \text{ mbar}}{\text{span mbar}} \right) \text{ in \% of span}$</p> <p>In Digital Mode: ±0.075% of span. For URV below reference point (50 inH₂O), effect equals: $\pm 0.025 + 0.05 \left(\frac{50 \text{ inH}_2\text{O}}{\text{span inH}_2\text{O}} \right) \text{ or } \pm 0.025 + 0.05 \left(\frac{125 \text{ mbar}}{\text{span mbar}} \right) \text{ in \% of span}$</p>
Zero Static Pressure Effect per 1000 psi (70 bar)	<p>±0.075% of span. For URV below reference point (50 inH₂O), effect equals: $\pm 0.0125 + 0.0625 \left(\frac{50 \text{ inH}_2\text{O}}{\text{span inH}_2\text{O}} \right) \text{ or } \pm 0.0125 + 0.0625 \left(\frac{125 \text{ mbar}}{\text{span mbar}} \right) \text{ in \% of span}$</p>
Combined Zero and Span Static Pressure Effect per 1000 psi (70 bar)	<p>±0.15% of span. For URV below reference point (50 inH₂O), effect equals: $\pm 0.0875 + 0.0625 \left(\frac{50 \text{ inH}_2\text{O}}{\text{span inH}_2\text{O}} \right) \text{ or } \pm 0.0875 + 0.0625 \left(\frac{125 \text{ mbar}}{\text{span mbar}} \right) \text{ in \% of span}$</p>
Stability	±0.015% of URL per year.

* Performance specifications are based on reference conditions of 25°C (77°F), zero (0) static pressure, 10 to 55% RH, and 316 Stainless Steel barrier diaphragm.

Performance Under Rated Conditions* - Model STF13F (0 to 100 psi)

Parameter	Description
Upper Range Limit psi bar	100 7
Minimum Span psi bar	5 0.35
Turndown Ratio	20 to 1
Zero Elevation and Suppression	No limit except minimum span within –18 and +100% URL. Specifications valid from –5 to +100% URL.
Accuracy (Reference – Includes combined effects of linearity, hysteresis, and repeatability) <ul style="list-style-type: none"> • Accuracy includes residual error after averaging successive readings. • For FOUNDATION Fieldbus use Digital Mode specifications. For HART use Analog Mode specifications. 	In Analog Mode: ±0.075% of calibrated span or upper range value (URV), whichever is greater, terminal based. For URV below reference point (15 psi), accuracy equals: $\pm 0.025 + 0.05 \left(\frac{15 \text{ psi}}{\text{span psi}} \right)$ or $\pm 0.025 + 0.05 \left(\frac{1 \text{ bar}}{\text{span bar}} \right)$ in % of span In Digital Mode: ±0.0625% of calibrated span or upper range value (URV), whichever is greater, terminal based. For URV below reference point (15 psi), accuracy equals: $\pm 0.0125 + 0.05 \left(\frac{15 \text{ psi}}{\text{span psi}} \right)$ or $\pm 0.0125 + 0.05 \left(\frac{1 \text{ bar}}{\text{span bar}} \right)$ in % of span
Zero Temperature Effect per 28°C (50°F)	In Analog Mode: ±0.0625% of span. For URV below reference point (30 psi), effect equals: $\pm 0.0125 + 0.05 \left(\frac{30 \text{ psi}}{\text{span psi}} \right)$ or $\pm 0.0125 + 0.05 \left(\frac{2 \text{ bar}}{\text{span bar}} \right)$ in % of span In Digital Mode: ±0.05% of span. For URV below reference point (30 psi), effect equals: $\pm 0.05 \left(\frac{30 \text{ psi}}{\text{span psi}} \right)$ or $\pm 0.05 \left(\frac{2 \text{ bar}}{\text{span bar}} \right)$ in % of span
Combined Zero and Span Temperature Effect per 28°C (50°F)	In Analog Mode: ±0.10% of span. For URV below reference point (30 psi), effect equals: $\pm 0.05 + 0.05 \left(\frac{30 \text{ psi}}{\text{span psi}} \right)$ or $\pm 0.05 + 0.05 \left(\frac{2 \text{ bar}}{\text{span bar}} \right)$ in % of span In Digital Mode: ±0.075% of span. For URV below reference point (30 psi), effect equals: $\pm 0.025 + 0.05 \left(\frac{30 \text{ psi}}{\text{span psi}} \right)$ or $\pm 0.025 + 0.05 \left(\frac{2 \text{ bar}}{\text{span bar}} \right)$ in % of span
Zero Static Pressure Effect per 1000 psi (70 bar)	±0.075% of span. For URV below reference point (30 psi), effect equals: $\pm 0.0125 + 0.0625 \left(\frac{30 \text{ psi}}{\text{span psi}} \right)$ or $\pm 0.0125 + 0.0625 \left(\frac{2 \text{ bar}}{\text{span bar}} \right)$ in % of span
Combined Zero and Span Static Pressure Effect per 1000 psi (70 bar)	±0.15% of span. For URV below reference point (30 psi), effect equals: $\pm 0.0875 + 0.0625 \left(\frac{30 \text{ psi}}{\text{span psi}} \right)$ or $\pm 0.0875 + 0.0625 \left(\frac{2 \text{ bar}}{\text{span bar}} \right)$ in % of span
Stability	±0.04% of URL per year.

* Performance specifications are based on reference conditions of 25°C (77°F), zero (0) static pressure, 10 to 55% RH, and 316 Stainless Steel barrier diaphragm.

Performance Under Rated Conditions* - Model STF14F (0 to 600 inH₂O)

Parameter	Description
Upper Range Limit inH ₂ O mbar	600 (39.2°F/4°C is standard reference temperature for inH ₂ O range.) 1500
Minimum Span inH ₂ O mbar	25 62.2
Turndown Ratio	24 to 1
Zero Elevation and Suppression	No limit except minimum span within 0 to 100% URL.
Accuracy (Reference – Includes combined effects of linearity, hysteresis, and repeatability) <ul style="list-style-type: none"> Accuracy includes residual error after averaging successive readings. For FOUNDATION Fieldbus use Digital Mode specifications. For HART use Analog Mode specifications. 	In Analog Mode: ±0.075% of calibrated span or upper range value (URV), whichever is greater, terminal based. For URV below reference point (25 inH ₂ O), accuracy equals: $\pm 0.0375 + 0.0375 \left(\frac{25 \text{ inH}_2\text{O}}{\text{span inH}_2\text{O}} \right)$ or $\pm 0.0375 + 0.0375 \left(\frac{62 \text{ mbar}}{\text{span mbar}} \right)$ in % of span In Digital Mode: ±0.05% of calibrated span or upper range value (URV), whichever is greater, terminal based. For URV below reference point (25 inH ₂ O), accuracy equals: $\pm 0.0125 + 0.0375 \left(\frac{25 \text{ inH}_2\text{O}}{\text{span inH}_2\text{O}} \right)$ or $\pm 0.0125 + 0.0375 \left(\frac{62 \text{ mbar}}{\text{span mbar}} \right)$ in % of span
Zero Temperature Effect per 28°C (50°F)	In Analog Mode: ±0.0625% of span. For URV below reference point (50 inH ₂ O), effect equals: $\pm 0.0125 + 0.05 \left(\frac{50 \text{ inH}_2\text{O}}{\text{span inH}_2\text{O}} \right)$ or $\pm 0.0125 + 0.05 \left(\frac{125 \text{ mbar}}{\text{span mbar}} \right)$ in % of span In Digital Mode: ±0.05% of span. For URV below reference point (50 inH ₂ O), effect equals: $\pm 0.05 \left(\frac{50 \text{ inH}_2\text{O}}{\text{span inH}_2\text{O}} \right)$ or $\pm 0.05 \left(\frac{125 \text{ mbar}}{\text{span mbar}} \right)$ in % of span
Combined Zero and Span Temperature Effect per 28°C (50°F)	In Analog Mode: ±0.10% of span. For URV below reference point (50 inH ₂ O), effect equals: $\pm 0.05 + 0.05 \left(\frac{50 \text{ inH}_2\text{O}}{\text{span inH}_2\text{O}} \right)$ or $\pm 0.05 + 0.05 \left(\frac{125 \text{ mbar}}{\text{span mbar}} \right)$ in % of span In Digital Mode: ±0.075% of span. For URV below reference point (50 inH ₂ O), effect equals: $\pm 0.025 + 0.05 \left(\frac{50 \text{ inH}_2\text{O}}{\text{span inH}_2\text{O}} \right)$ or $\pm 0.025 + 0.05 \left(\frac{125 \text{ mbar}}{\text{span mbar}} \right)$ in % of span
Zero Static Pressure Effect per 1000 psi (70 bar)	±0.075% of span. For URV below reference point (50 inH ₂ O), effect equals: $\pm 0.0125 + 0.0625 \left(\frac{50 \text{ inH}_2\text{O}}{\text{span inH}_2\text{O}} \right)$ or $\pm 0.0125 + 0.0625 \left(\frac{125 \text{ mbar}}{\text{span mbar}} \right)$ in % of span
Combined Zero and Span Static Pressure Effect per 1000 psi (70 bar)	±0.20% of span. For URV below reference point (50 inH ₂ O), effect equals: $\pm 0.1375 + 0.0625 \left(\frac{50 \text{ inH}_2\text{O}}{\text{span inH}_2\text{O}} \right)$ or $\pm 0.1375 + 0.0625 \left(\frac{125 \text{ mbar}}{\text{span mbar}} \right)$ in % of span
Stability	±0.04% URL per year

* Performance specifications are based on reference conditions of 25°C (77°F), zero (0) static pressure, 10 to 55% RH, and 316 Stainless Steel barrier diaphragm.

Performance Under Rated Conditions - General for all Models

Parameter	Description
Output (two-wire)	Analog 4 to 20 mA or digital communications DE mode. Options available for FOUNDATION Fieldbus and HART protocol.
Supply Voltage Effect	0.005% of span per volt.
Damping Time Constant	Adjustable from 0 to 32 seconds digital damping.
CE Conformity (Europe)	89/336/EEC, Electromagnetic Compatibility (EMC) Directive.
NAMUR NE 43 Compliance Option	Transmitter failure information is generated when the measuring information is invalid or no longer present. Failure information is transmitted as a current signal but outside the normal 4-20 mA measurement signal level. Transmitter failure values are: ≤ 3.6 mA and ≥ 21.0 mA. The normal signal range is ≥ 3.8 mA and ≤ 20.5 mA.
SIL 2/3 Compliance	SIL certified to IEC 61508 for non-redundant use in SIL 2 related Safety Systems (single use) and for redundant (multiple) use in SIL 3 Safety Systems through TÜV Nord Sys Tec GmbH & Co. KG under the following standards: IEC61508-1: 1998; IEC 61508-2: 2000; IEC61508-3: 1998.
Lightning Protection Option (Code "LP")	Leakage Current: 10 microamps max. @ 42.4 VDC, 93°C Impulse Rating: 10/20 μ sec. 5,000 Amps (50 strikes) 10,000 Amps (20 strikes) (rise/decay) 10/1000 μ sec. 250 Amps (1000 strikes) 500 Amps (400 strikes)

Physical and Approval Bodies

Parameter	Description
Barrier Diaphragms Material (Wetted)	316L SS, Hastelloy C-276, Monel**
Gasket Ring Material (Wetted)	316/316L SS, Hastelloy C-276*, Monel**
Extension Tube Material	316 SS
Process Head and Adapter Flange Material	316 SS, Carbon Steel (Zinc-plated), Monel*, Hastelloy C-276*
Process Head Gaskets	Teflon is standard.
Meter Body Bolting	Carbon Steel or 316 SS (NACE) bolts.
Mounting Flange STF128, STF132	Flush or Extended Diaphragm: Zinc Chromate plated Carbon Steel, 304 SS, or 316 SS.
STF12F, STF13F, STF14F	316L SS (NOTE: Mounting Flange is process wetted.)
Fill Fluid	Silicone oil or CTFE (Chlorotrifluoroethylene)
Electronic Housing	Epoxy-Polyester hybrid paint. Low Copper-Aluminum. Meets NEMA 4X (watertight) and NEMA 7 (explosion proof). Stainless Steel optional.
Process Connections All Models STF128, STF132	Process Head: 1/4-inch NPT; 1/2-inch NPT with adapter and DIN, standard options. Flange: 2, 3 or 4-inch Class 150 or 300 ANSI; DN50-PN40, DN80-PN40 or DN100-PN40 DIN flange. Extended Diaphragm: 2, 4, or 6 inches (50, 101, 152 mm) long.
STF12F, STF13F, STF14F	2 or 3-inch, Class 150 ANSI flange.
Wiring	Accepts up to 16 AWG (1.5 mm diameter).
Mounting	See Figure 3 for typical flange mounting arrangement.
Dimensions	See Figures 4, 5, and 6

Table continued on next page

Physical and Approval Bodies, continued

Parameter	Description
Net Weight STF128, STF132 STF12F, STF13F, STF14F	Flush or Extended Model: 15.5 to 35.0 pounds (7 to 16 Kg) depending on flange size 14.2 to 18.4 pounds (6.5 to 9 Kg) depending on flange size
Approval Bodies	
Factory Mutual	Explosion Proof: Approved as Explosion Proof for Class I, Division 1, Groups A, B, C, D locations, Dust Ignition Proof: Approved as Dust Ignition Proof for Class II, III, Division 1, Groups E, F, G locations, Intrinsically Safe: Approved as Intrinsically Safe for for Class I, II, III, Division 1, Groups A, B, C, D, E, F, G locations. Nonincendive: Approved as Nonincendive for Class I, Division 2, Groups A, B, C, D locations.
CSA	Explosion Proof: Approved as Explosion Proof for Class I, Division 1, Groups B, C, D locations, Dust Ignition Proof: Approved as Dust Ignition Proof for Class II, III, Division 1, Groups E, F, G locations, Intrinsically Safe: Approved as Intrinsically Safe for Class I, II, III, Division 1, Groups A, B, C, D, E, F, G locations.
Canadian Registration Number (CRN)	All ST 3000 model designs, except SATG19L, STG99L, STG170 and STG180 have been registered in all provinces and territories in Canada and are marked CRN:0F8914.5c.
ATEX	Intrinsically Safe, Zone 0/1: EEx ia IIC T4, T5, T6 Flameproof/Zone 1: EEx d IIC T5, T6 (enclosure IP 66/67) Non-Sparking, Zone 2: EEx nA, IIC T6 (enclosure IP 66/67) Multiple Markings: Ex II 1 G: EEx ia IIC T4, T5, T6, Ex II 2 G: EExd IIC T5, T6 Ex II 3 G: EEx nA, IIC T6 (Honeywell) (enclosure IP 66/67)
SA (Australian)	Intrinsically Safe: EX ia IIC T4 Non-Sparking: Ex n IIC T6 (T4 with SM option)
INMETRO (Brazil)	Flame-Proof, Zone 1: EX d IIC T5
Pressure Equipment Directive (97/23/EC)	The ST 3000 pressure transmitters listed in this Specification have no pressurized internal volume or have a pressurized internal volume rated less than 1,000 bar (14,500 psig) and/or have a maximum volume of less than 0.1 liter. Therefore, these transmitters are either; not subject to the essential requirements of the directive 97/23/EC (PED, Annex 1) and shall not have the CE mark, or the manufacturer has the free choice of a module when the CE mark is required for pressures > 200 bar (2,900 psig).

NOTE: Pressure transmitters that are part of safety equipment for the protection of piping (systems) or vessel(s) from exceeding allowable pressure limits, (equipment with safety functions in accordance with Pressure Equipment Directive 97/23/EC article 1, 2.1.3), require separate examination.

* Flush design only.

**Flush or pseudo flange design.

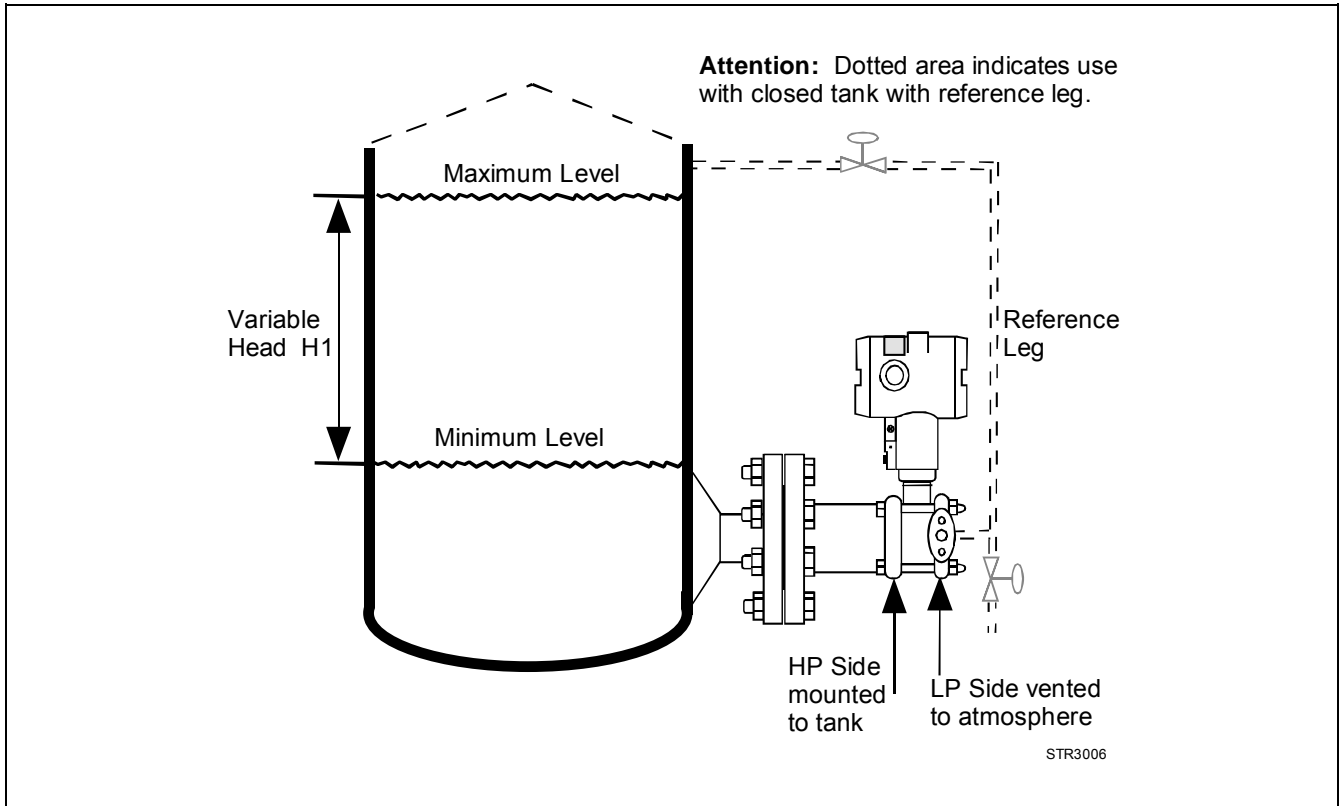

Figure 3 - Typical mounting arrangement for flange mounted liquid level transmitter.

Reference Dimensions: $\frac{\text{millimeters}}{\text{inches}}$

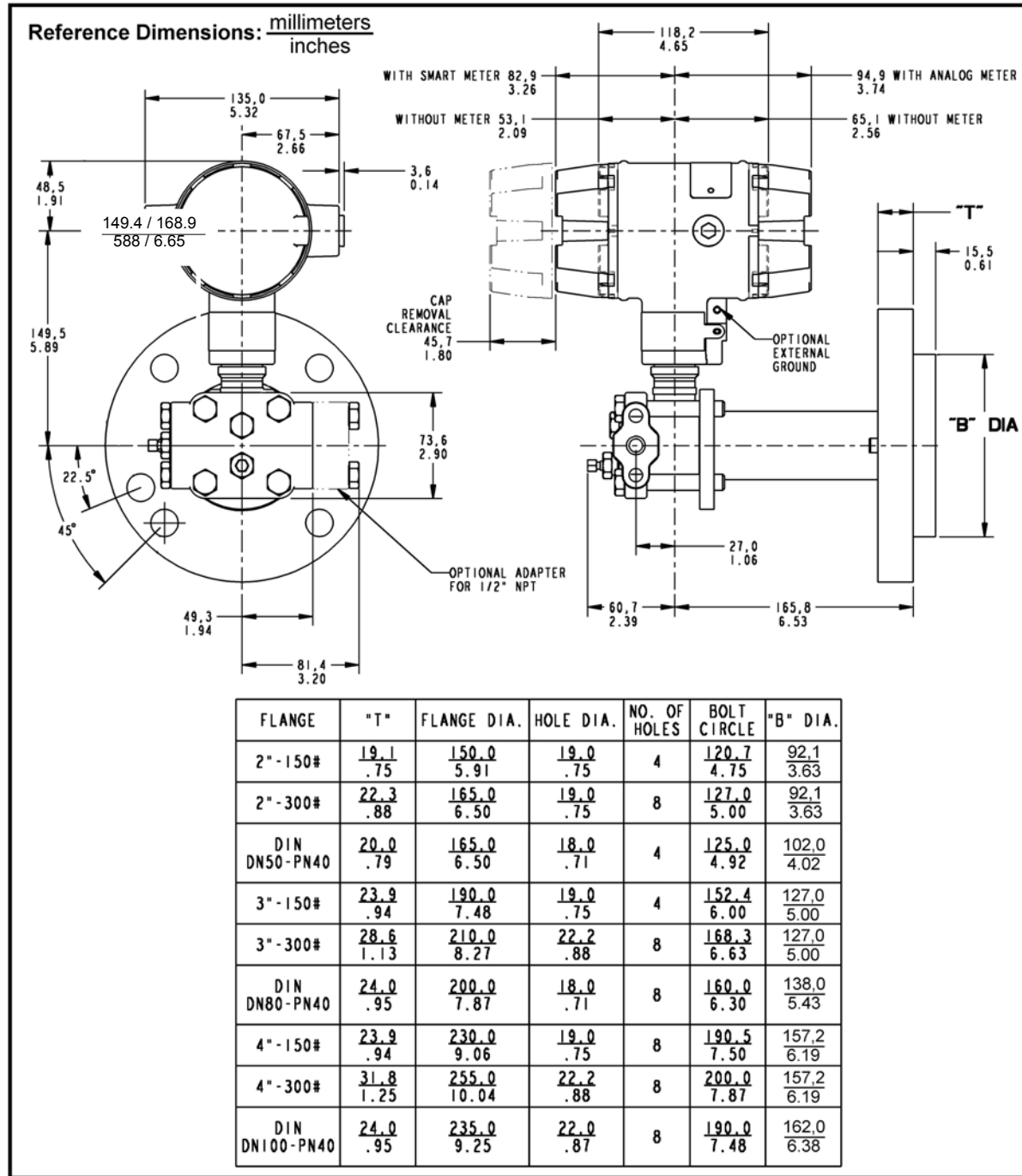

Figure 4 - Approximate mounting dimensions for flush diaphragm type models STF128 and STF132.

Reference Dimensions: $\frac{\text{millimeters}}{\text{inches}}$

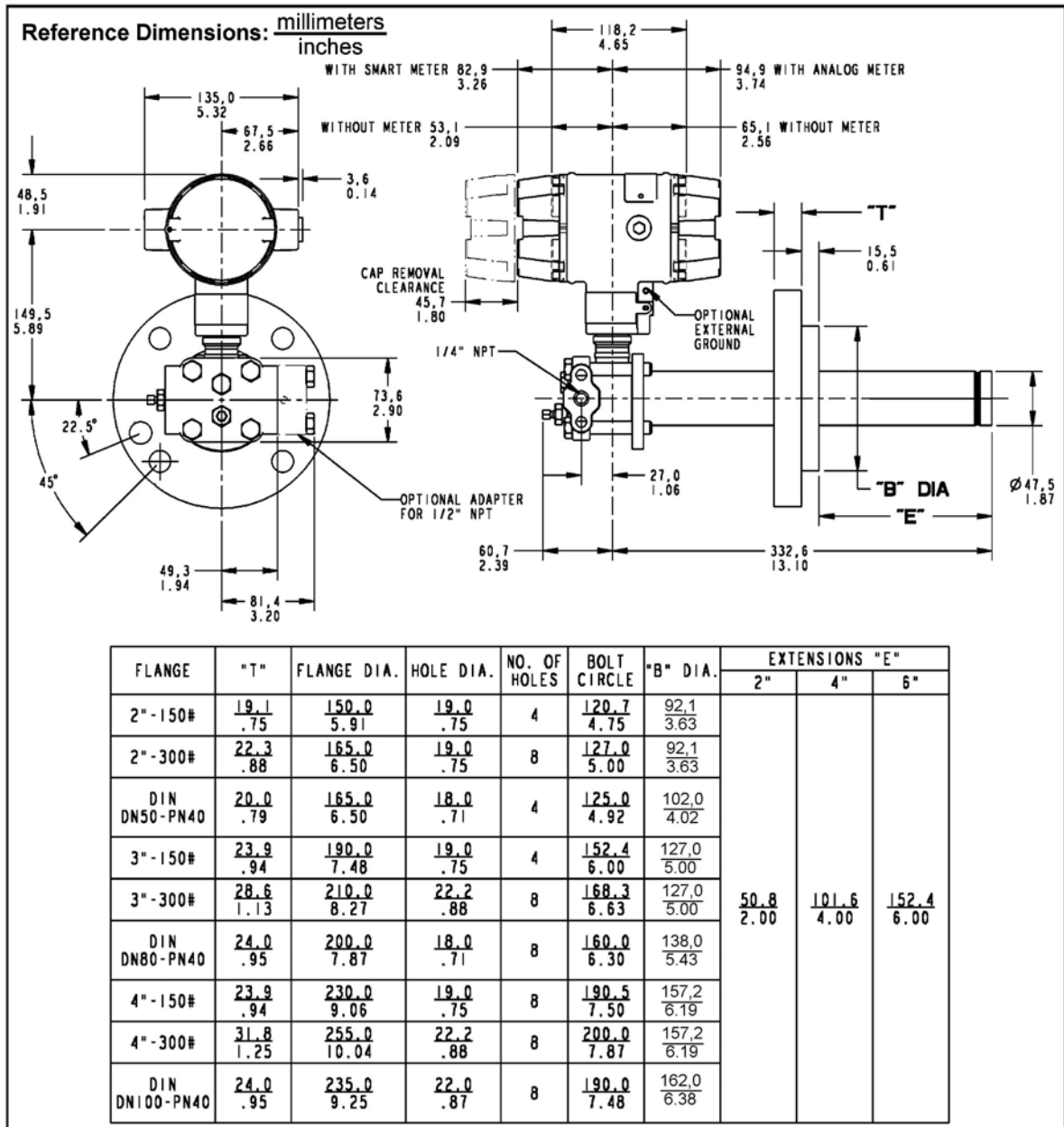

Figure 5 - Approximate mounting dimensions for extended diaphragm type models STF128 and STF132.

Reference Dimensions: $\frac{\text{millimeters}}{\text{inches}}$

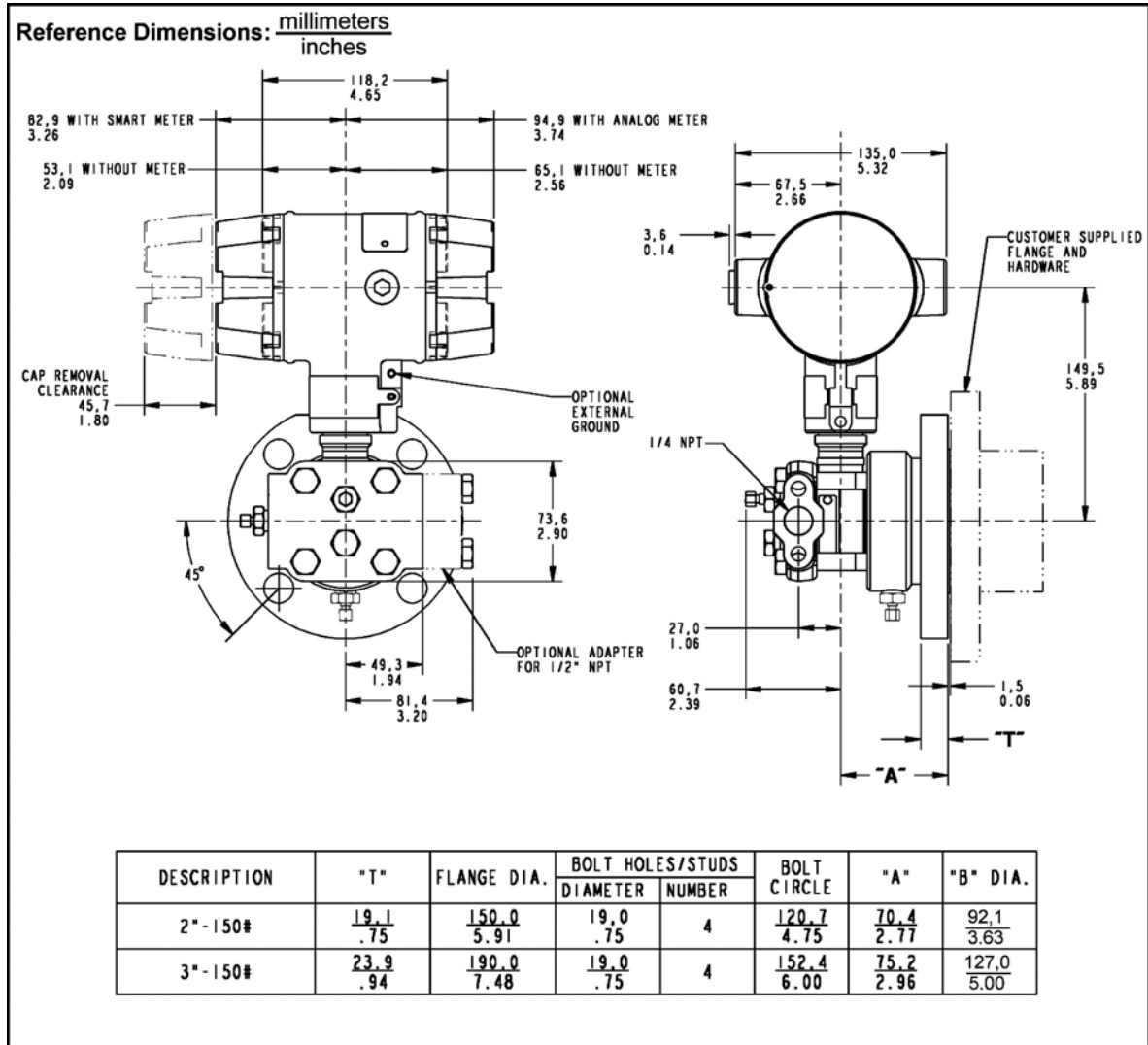

Figure 6 - Approximate mounting dimensions for pseudo flange type models STF12F, STF13F, and STF14F.

Options	Ordering Information
<p>Indicating Meter (Options ME and SM) Two integral meter options are available. An analog meter (option ME) is available with a 0 to 100% linear scale. The Smart Meter (option SM) provides an LCD display for both analog and digital output and can be configured to display pressure in pre-selected engineering units.</p> <p>Lightning Protection (Option LP) A terminal block is available with circuitry that protects the transmitter from transient surges induced by nearby lightning strikes.</p> <p>HART® Protocol Compatibility (Options HC and H6) Optional electronics modules for the ST 3000 provides HART Protocol compatibility in either HART 5.x or 6.x formats. Transmitters with a HART Option are compatible with any HART enabled system that provides 5.x or 6.x format support.</p> <p>FOUNDATION Fieldbus (Option FF) Equips transmitter with FF protocol for use in 31.25 kbit/s FF networks. See document 34-ST-03-72 for additional information on ST 3000 Fieldbus transmitters.</p> <p>SIL2/SIL3 Certification (Option SL) This ST 3000 product is available for use with safety systems. With the SL option, we are fully certified to SIL 2 capability for single transmitters and SIL 3 capability for multiple transmitter use through TÜV Nord Sys Tec GmbH & Co. KG. We are in compliance with the following SIL standards: IEC 61508-1: 1998; IEC 61508-2: 2000; IEC 61508-3: 1998</p> <p>NAMUR NE43 Compliance (Option NE) This option provides software the meets the NAMUR NE43 requirements for failsafe software. Transmitter failure information is generated when the measuring information is no longer valid. Transmitter failure values are: ≤ 3.6 mA and ≥ 21.0 mA. The normal ST 3000 ranges are ≤ 3.8 mA and ≥ 20.5 mA.</p> <p>Tagging (Option TG) Up to 30 characters can be added on the stainless steel nameplate mounted on the transmitter's electronics housing at no extra cost. Note that a separate nameplate on the meter body contains the serial number and body-related data. A stainless steel wired on tag with additional data of up to 4 lines of 28 characters is also available. The number of characters for tagging includes spaces.</p> <p>Lifetime Warranty (Option WL) Extends limited 1-year warranty policy to 15 years for ST 3000 S100 pressure transmitters. See Honeywell Terms and Conditions</p> <p>Indicator Configuration (Option CI) Provides custom configuration of Smart Meters.</p> <p>Transmitter Configuration (Option TC) The factory can configure the transmitter linear/square root extraction, damping time, LRV, URV and mode (analog/digital) and enter an ID tag of up to eight characters and scratchpad information as specified.</p> <p>Custom Calibration and ID in Memory (Option CC) The factory can calibrate any range within the scope of the transmitter's range and enter an ID tag of up to eight characters in the transmitter's memory.</p>	<p>Contact your nearest Honeywell sales office, or</p> <p>In the U.S.: Honeywell Industrial Automation & Control 16404 North Black Canyon Hwy. Phoenix, AZ 85053 1-800-288-7491</p> <p>In Canada: The Honeywell Centre 155 Gordon Baker Rd. North York, Ontario M2H 3N7 1-800-461-0013</p> <p>In Latin America: Honeywell Inc. 480 Sawgrass Corporate Parkway, Suite 200 Sunrise, FL 33325 (954) 845-2600</p> <p>In Europe and Africa: Honeywell S. A. Avenue du Bourget 1 1140 Brussels, Belgium</p> <p>In Eastern Europe: Honeywell Praha, s.r.o. Budejovicka 1 140 21 Prague 4, Czech Republic</p> <p>In the Middle East: Honeywell Middle East Ltd. Khalifa Street, Sheikh Faisal Building Abu Dhabi, U. A. E.</p> <p>In Asia: Honeywell Asia Pacific Inc. Honeywell Building, 17 Changi Business Park Central 1 Singapore 486073 Republic of Singapore</p> <p>In the Pacific: Honeywell Pty Ltd. 5 Thomas Holt Drive North Ryde NSW Australia 2113 (61 2) 9353 7000</p> <p>In Japan: Honeywell K.K. 14-6 Shibaura 1-chrome Minato-ku, Tokyo, Japan 105-0023</p> <p>Or, visit Honeywell on the World Wide Web at: http://www.honeywell.com</p> <p><i>Specifications are subject to change without notice.</i></p>

Model Selection Guide (34-ST-16-21)

Instructions

- Select the desired Key Number. The arrow to the right marks the selection available.
 - Make one selection from each Table I and II using the column below the proper arrow.
 - Select as many Table III options as desired (if no options or approvals are desired, specify 9X).
 - A (*) denotes unrestricted availability. A letter denotes restricted availability.
 - Restrictions follow Table IV.
- Key Number - I - II - III (Optional) + IV
XXXX

KEY NUMBER

Span	Selection	Availability		
0-10" to 0-400" H ₂ O/0-25 to 0-1000 mbar Compound Characterized	STF128	↓		
0-5 to 0-100 psi/0-0.34 to 7 bar Compound Characterized	STF132	↓		
0-1" to 0-400" H ₂ O/0-2.5 to 0-1000 mbar	STF12F		↓	
0-5 to 0-100 psi/0-0.34 to 0-7 bar	STF13F		↓	
0-25" to 0-600" H ₂ O/0-62.2 to 0-1500 mbar	STF14F			↓

TABLE I - METER BODY

	Design	Ref. Hd.	** Vent Drain Valve on Ref. Head	Barrier Diaphragm. (wetted)	Diaphragm. Plate (wetted)	Extension (wetted)					
Materials of Construction	Flush	Carbon* Steel	316 SS	316L SS	316L SS	N/A	A __	•	•		
				Hast C	316L SS		W __	•			
				Hast C	Hast C		B __	•			
				Monel	Monel		C __	•			
		316 SS		316L SS	316L SS	E __	•				
				Hast C	316L SS	X __	•				
				Hast C	Hast C	F __	•				
				Monel	Monel	G __	•				
		Hast C	Hast C	Hast C	Hast C	J __	•				
		Monel	Monel	Monel	Monel	L __	•				
		Extended	Carbon* Steel	316 SS	316L SS	316L SS	316L SS	M __	•		
					Hast C			N __	•		
		316 SS		316L SS			R __	•			
				Hast C			S __	•			
	Pseudo Flange	Carbon* Steel	316 SS	316L SS	N/A	N/A	A __		•	•	
				Hast C			B __		•		
				Monel			C __		•		
		316 SS		316L SS			E __		•	•	
				Hast C			F __		•		
				Monel			G __		•		
Fill Fluid (Meter Body & Flange)	Silicone						- 1 -	•	•	•	
	CTFE						- 2 -	•	•		
Process Connection	Reference Head			Flange		Sel.					
	1/4" NPT			High Pressure Side		-- A	•	•	•		
	1/4" NPT			Low Pressure Side		-- C		•	•		
	1/2" NPT (with Adapter)			High Pressure Side		-- H	t	t	t		
	1/2" NPT (with Adapter)			Low Pressure Side		-- K		t	t		

* Carbon Steel heads are zinc-plated and not recommended for water service due to hydrogen migration. For that service, use 316 stainless steel wetted Process Heads.

** Vent/Drains are Teflon coated for lubricity.

Model Selection Guide (34-ST-16-21, cont)

TABLE II - FLANGE ASSEMBLY			Selection	Availability			
				28 32	2F 3F	4F	
No Selection	No Selection		0	.	.	.	
Flange (ANSI Flanges have 125-500 AARH Surface Finish)	3" ANSI Class 150	Carbon Steel (non-wetted)	- 1	.			
	3" ANSI Class 300		- 2	.			
	DN80-PN40 DIN		- 3	.			
	4" ANSI Class 150		- 4	.			
	4" ANSI Class 300		- 5	.			
	DN100-PN40 DIN		- 6	.			
	2" ANSI Class 150		- 7	.			
	2" ANSI Class 300		- 8	.			
	DN50-PN40 DIN		- 9	.			
	3" ANSI Class 150	304 SS (non-wetted)	- A	.			
	3" ANSI Class 300		- B	.			
	DN80-PN40 DIN		- C	.			
	4" ANSI Class 150		- D	.			
	4" ANSI Class 300		- E	.			
	DN100-PN40 DIN		- F	.			
	2" ANSI Class 150		- Q	.			
	2" ANSI Class 300		- U	.			
	DN50-PN40 DIN		- V	.			
	3" ANSI Class 150	316 SS (non-wetted)	- H	.			
	3" ANSI Class 300		- J	.			
DN80-PN40 DIN	- K		.				
4" ANSI Class 150	- L		.				
4" ANSI Class 300	- M		.				
DN100-PN40 DIN	- N		.				
2" ANSI Class 150	- W		.				
2" ANSI Class 300	- X		.				
DN50-PN40 DIN	- Y		.				
Pseudo Flange on Standard DP	316L SS (wetted)	- T		.	.		
2" ANSI Class 150 w/Vent/Drain		- R		.	.		
3" ANSI Class 150 w/Vent/Drain		- P		.	.		
No Selection			- 0		.	.	
Gasket Ring (wetted)	Flush Design	316L SS	- 1	g			
		Hast C	- 2	g			
		Monel	- 3	q			
Extended Design		316L SS	- 5	v			
Extension (wetted)	No Selection		- 0		.	.	
	Flush		- F	h			
	1.87 Inches (for 2", 3" or 4" spud)***	Diameter	Length	- C	v		
			2 inches	- D	v		
			4 inches	- E	v		
	6 inches						
No Selection	No Selection		- 0	.	.	.	

*** For part numbers and pricing information on Tank Spuds refer to page ST-91 (Supplementary Accessories & Kits).

Model Selection Guide (34-ST-16-21, cont)

TABLE III - OPTIONS	Selection	STF1xx			
		28 32	2F 3F	4F	
None	00	.	.	.	
Communication Options					
HART 5.x Protocol Compatible Electronics	HC	z	z	z	b
HART 6.x Protocol Compatible Electronics	H6	z	z	z	b
FOUNDATION Fieldbus Communications	FF	r	r	r	b
Indicating Meter Options					
Analog Meter (0-100 Even 0-10 Square Root)	ME	.	.	.	b
Smart Meter	SM	.	.	.	b
Custom Configuration of Smart Meter	CI	e	e	e	
Local Zero & Span	ZS	m	m	m	b
Local Zero	LZ	x	x	x	b
Transmitter Housing & Electronics Options					
NAMUR Failsafe Software	NE	15	15	15	
SIL 2 - TÜV Certified transmitter (requires HC and WP options)	SL	p	p	p	
Lightning Protection	LP	.	.	.	
Custom Calibration and I.D. in Memory	CC	.	.	.	
Transmitter Configuration - non-Fieldbus	TC	.	.	.	
Write Protection (Delivered in the "enabled" position)	WP	.	.	.	b
Write Protection (Delivered in the "disabled" position)	WX	.	.	.	b
316 SS Electronics Housing - with M20 Conduit Connections	SH	n	n	n	b
1/2" NPT to M20 316 SS Conduit Adapter (BASEEFA EEEx d IIC)	A1	n	n	n	b
1/2" NPT to 3/4" NPT 316 SS Conduit Adapter	A2	u	u	u	
Stainless Steel Housing with M20 to 1/2" NPT 316 SS Conduit Adapter (use for FM and CSA Approvals)	A3	i	i	i	
Stainless Steel Customer Wired-On Tag (4 lines, 28 characters per line, customer supplied information)	TG	.	.	.	
Stainless Steel Customer Wired-On Tag (blank)	TB	.	.	.	
End Cap Live Circuit Warning Label in Spanish (only with ATEX 3D)	SP	a	a	a	b
End Cap Live Circuit Warning Label in Portuguese (only with ATEX 3D)	PG	a	a	a	b
End Cap Live Circuit Warning Label in Italian (only with ATEX 3D)	TL	a	a	a	b
End Cap Live Circuit Warning Label in German (only with ATEX 3D)	GE	a	a	a	b
Meter Body Options					
316 SS (NACE) Bolts and 304 SS (NACE) Retaining Ring for Heads	CR	.	.	.	b
316 SS Bolts and 316 SS Nuts for Process Heads	SS	.	.	.	b
B7M Bolts and Nuts for Process Heads	B7	.	.	.	b
316 SS Adapter Flange - 1/2" NPT with CS Bolts	S2	c	c	c	
316 SS Adapter Flange - 1/2" NPT with 316 SS Bolts	S3	c	c	c	
316 SS Adapter Flange - 1/2" NPT with NACE A286 SS Bolts	S4	c	c	c	
316 SS Adapter Flange - 1/2" NPT with B7M Bolts	S5	c	c	c	
Hastelloy C Adapter Flange - 1/2" NPT with CS Bolts	T2	c	c	c	b
Hastelloy C Adapter Flange - 1/2" NPT with 316 SS Bolts	T3	c	c	c	b
Monel Adapter Flange - 1/2" NPT with CS Bolts	V2	c	c	c	
Monel Adapter Flange - 1/2" NPT with 316 SS Bolts	V3	c	c	c	
316 SS Blind Adapter Flange with CS Bolts	B3	.	.	.	b
316 SS Blind Adapter Flange with 316 SS Bolts	B4	.	.	.	b
316 SS Blind Adapter Flange with NACE A286 SS Bolts	B5	.	.	.	b
316 SS Blind Adapter Flange with B7M Bolts	B6	.	.	.	b
316 SS Center Vent Drain and Bushing	CV	.	.	.	
Viton Process Head Gaskets (adapter gaskets ordered separately)	VT	.	.	.	
Viton Adapter Flange Gaskets	VF	17	17	17	
Services/Certificates/Marine Type Approval Options					
User's Manual Paper Copy (Standard, HC, or FF ships accordingly)	UM	.	.	.	
Clean Transmitter for Oxygen or Chlorine Service with Certificate	OX	j	j	.	
Over-Pressure Leak Test with F3392 Certificate	TP	.	.	.	
Calibration Test Report and Certificate of Conformance (F3399)	F1	.	.	.	b
Certificate of Conformance (F3391)	F3	.	.	.	b
Certificate of Origin (F0195)	F5	.	.	.	
FMEDA Certificate (SIL 1)	F6	.	.	.	
NACE Certificate (F0198)	F7	o	o	o	
Marine Type Approvals (DNV, ABS, BV & LR)	MT	.	.	.	
Warranty Options					
Additional Warranty - 1 year	W1	.	.	.	b
Additional Warranty - 2 years	W2	.	.	.	b
Additional Warranty - 3 years	W3	.	.	.	b
Additional Warranty - 4 years	W4	.	.	.	b
Lifetime Warranty - 15 years	WL	.	.	.	b

Table III continued next page

Model Selection Guide (34-ST-16-21, cont)

Availability

STF1xx ↓ ↓ ↓

TABLE III - OPTIONS (continued)

Approval Body	Approval Type	Location or Classification	Selection	Availability		
				28 32	2F 3F	4F
No hazardous location approvals			9X	•	•	•
Factory Mutual	Explosion Proof	Class I, Div. 1, Groups A,B,C,D	1C	•	•	•
	Dust Ignition Proof	Class II, III Div. 1, Groups E,F,G		•	•	•
	Non-Incendive	Class I, Div. 2, Groups A,B,C,D		•	•	•
	Intrinsically Safe	Class I, II, III, Div. 1, Groups A,B,C,D,E,F,G		•	•	•
CSA	Explosion Proof	Class I, Div. 1, Groups B,C,D	2J	•	•	•
	Dust Ignition Proof	Class II, III, Div. 1, Groups E,F,G		•	•	•
	Intrinsically Safe	Class I, II, III, Div. 1, Groups A,B,C,D,E,F,G		•	•	•
SA (Australia)	Intrinsically Safe	Ex ia IIC T4	4G	•	•	•
	Non-Sparking	Ex n IIC T6 (T4 with SM option)		•	•	•
ATEX*	Intrinsically Safe, Zone 0/1	Ex II 1 G EEx ia IIC T4, T5, T6	3S	•	•	•
	Flameproof, Zone 1	Ex II 2 G EEx d IIC T5, T6, Enclosure IP 66/67	3D	•	•	•
	Non-Sparking, Zone 2	Ex II 3 G EEx nA, IIC T6 (Honeywell). Enclosure IP 66/67	3N	•	•	•
	Multiple Marking**	Ex II 1 G EEx ia IIC T4, T5, T6	3H	•	•	•
	Int. Safe, Zone 0/1, or Flameproof, Zone 1, or Non-Sparking, Zone 2	Ex II 2 G EEx d IIC T5, T6 Ex II 3 G EEx nA, IIC T6 (Honeywell) Enclosure IP 66/67		•	•	•
INMETRO (Brazil)	Flameproof, Zone 1	Ex d IIC T5	6D	•	•	•

*See ATEX installation requirements in the ST 3000 User's Manual.

**The user must determine the type of protection required for installation of the equipment. The user shall then check the box [] adjacent to the type of protection used on the equipment certification nameplate. Once a type of protection has been checked on the nameplate, subsequently the equipment shall not be reinstalled using any of the other certification types.

TABLE IV

Factory Identification	XXXX	•	•	•
------------------------	------	---	---	---

RESTRICTIONS

Restriction Letter	Available Only With		Not Available With	
	Table	Selection	Table	Selection
a	III	3D or 3H		
b	Select only one option from this group			
c	I	H, K		
e	III	SM		
g		A __, B __, E __, F __, J __, __, X __		
h			I II	M __, N __, R __, S __ 5
i	III	1C or 2J		
j	I	2		
m			III	ME, FF
n			III	1C, 2J
o	III	CR or B1		
p	III	HC, WP	III	FF, 00
q	I	C __, G __, L __		
r			III	TC, ME, 4G, 3S
t	III	Select S2,S3,S4,S5,T2,T3,V2,V3		
u	III	1C, 2J		
v	I	M __, N __, R __, S __		
x	III	FF, SM		
z			III	4G
15			III	FF
17	III	VT		

Note: See ST-83 for Published Specials with pricing.
See ST-89 and User's Manual for part numbers.
See ST-OE-9 for OMS Order Entry Information including TC, manuals, certificates, drawings and SPINS.
See ST-OD-1 for tagging, ID, Transmitter Configuration (TC) and calibration including factory default values.
To request a quotation for a non-published "special", fax RFQ to Marketing Applications

ST 3000® is a registered trademark of Honeywell International Inc.
HART* is a trademark of the Hart Communication Foundation.
FOUNDATION™ is a trademark of the Fieldbus Foundation.

Honeywell

Honeywell Process Solutions
Industrial Measurement and Control
Honeywell International Inc.
2500 W. Union Hill Drive
Phoenix, Arizona 85027

©Honeywell International Inc.